

AN 829B DUAL BEAM POWER PENTODE CW TRANSMITTER

Don Huff, W6JL

June 6, 2016

I've always thought of the 829B as a rather attractive tube physically (ie, it has "sex appeal" :o)). So, having in hand a few of these WWII-era tubes and some matching sockets acquired over the years, I decided to take a break from my usual modern surface-mount technology homebrewing, and build a transmitter using this venerable twin beam power pentode. This has proven to be a very interesting and rewarding project, as I will elaborate on as we proceed.

The 829B was designed for VHF amplifier service, operating in push-pull. It is somewhat akin to a 'big brother' of the 832A, which was used in WWII aircraft transmitters such as the AN/ARC-1 VHF transmitters, which I played with, and modified, in my youth. (I had in fact built a 2-meter 829B amplifier in 1958. Now, some 58 years later, it was time to revisit my old friend the 829B).



**PUSH-PULL
BEAM POWER AT
200 MC**
*with these
RCA little wizards*

* Small but powerful, RCA-829 and RCA-832 are real buys for the ultra-highs: High efficiency at low plate voltage. Low driving power. High output. Compact. Rugged. Either 6.3 or 12.6-volt heater operation. Neutralization not required. High power-sensitivity simplifies transmitter design. Operates up to 200 mc at full ratings; up to 250 mc at reduced ratings. Army-Navy Preferred Type listing. Over three years of practical field application.

Excellent as frequency triplers and r-f power amplifiers, they give you worth-while advantages in UHF work—FM and AM transmitters, both mobile and fixed, for aviation, emergency, television, and military applications.

Equipment designers can obtain application data and assistance from RCA electron tube engineers. Please write, stating your problem, to Radio Corporation of America, Commercial Engineering Section, 565 South 5th Street, Harrison, New Jersey.

RCA-829—\$19.50 120 WATTS INPUT* AT 200 Mc Typical Operation, Class C telegraph (Continuous Commercial Service): plate volts, 500; plate current, 240 ma.; driving power, 0.7 watt; output, 83 watts.

RCA-832—\$17.00 36 WATTS INPUT* AT 200 Mc Typical Operation, Class C telegraph (Continuous Commercial Service): d-c plate volts, 500; d-c plate current, 72 ma.; driving power, 0.18 watt; output, 26 watts.

*Class C Telegraph

The Magic Brain of All Electronic Equipment is a Tube and the Fountain-Head of Modern Tube Development is RCA

TUNE IN "WHAT'S NEW?" RCA's great new show, Saturday nights, 7 to 8, E. W. T., Blue Network

BUY MORE WAR BONDS

GET YOUR COPY-354

Send today for the "RCA Guide for Transmitting Tubes" — 73 pages crammed with helpful information. Write to: RCA, 665 South 5th Street, Harrison, N. J.

RCA
RADIO CORPORATION OF AMERICA

RCA advertisement for the 829 in the 1944 edition of the Radio Amateur's Handbook. Note the list price of \$19.50, equivalent to perhaps \$200 or more today. New tubes and parts used by hams in homebrewing, even 70 years ago, were not inexpensive, as any perusal of old magazine advertisements will attest. By comparison, current devices used in modern homebrewing (and also, many tubes) are comparative bargains today.

829B

Twin Beam Power Tube

GENERAL DATA

Electrical:

Heater, for Unipotential Cathode:

	<i>Series</i>	<i>Parallel</i>	
Heater Arrangement			
Voltage (AC or DC)	12.6 ± 10%	6.3 ± 10%	volts
Current	1.125	2.250	amp

Transconductance (Each unit)
for dc plate volts = 250, dc
grid No.2 volts = 175, and dc
plate ma. = 60. 8500 μ mos

Mu-Factor, Grid No.2 to Grid
No.1 (Each unit) for dc plate
volts & dc grid No.2 volts =
225, and dc plate ma. = 60. 9

Direct Interelectrode Capacitances (Each unit):
Grid-No.1 to plate^a 0.12 max. pf
Grid No.1 to cathode & grid
No.3, grid No.2, and heater
Plate to cathode & grid No.3,
grid No.2, and heater 14.5 pf
7.0 pf

Grid-No.2-to-Cathode Capacitance including internal
grid-No.2 bypass capacitor
(Approx.) 65 pf

Mechanical:

Operating Position. Vertical, base up or down;
Horizontal, plane of each plate vertical
Overall Length. 4-1/8" ± 3/16"
Seated Length 3-11/16" ± 3/16"
Maximum Diameter. 2-3/8"
Bulb. T16
Bulb Terminals. See *Dimensional Outline*
Base. Medium Molded-Flare Septar 7-Pin (JEDEC No.7-2)
Basing Designation for BOTTOM VIEW. 7BP

- Pin 1- Heater
- Pin 2- Grid No.1 of Unit No.2
- Pin 3- Grid No.2
- Pin 4- Cathode, Grid No.3
- Pin 5- Heater Center-Tap

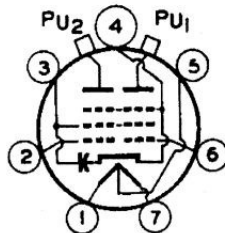

- Pin 6- Grid No.1 of Unit No.1
- Pin 7- Heater
- PU₁ - Plate of Unit No.1
- PU₂ - Plate of Unit No.2

AF POWER AMPLIFIER & MODULATOR — Class AB₁^b

Values are on a per-tube basis

Maximum CCS^c Ratings, Absolute-Maximum Values:

DC PLATE VOLTAGE. 750 max. volts
← indicates a change.



RADIO CORPORATION OF AMERICA
Electron Tube Division
Harrison, N. J.

DATA 1
7-63

829B

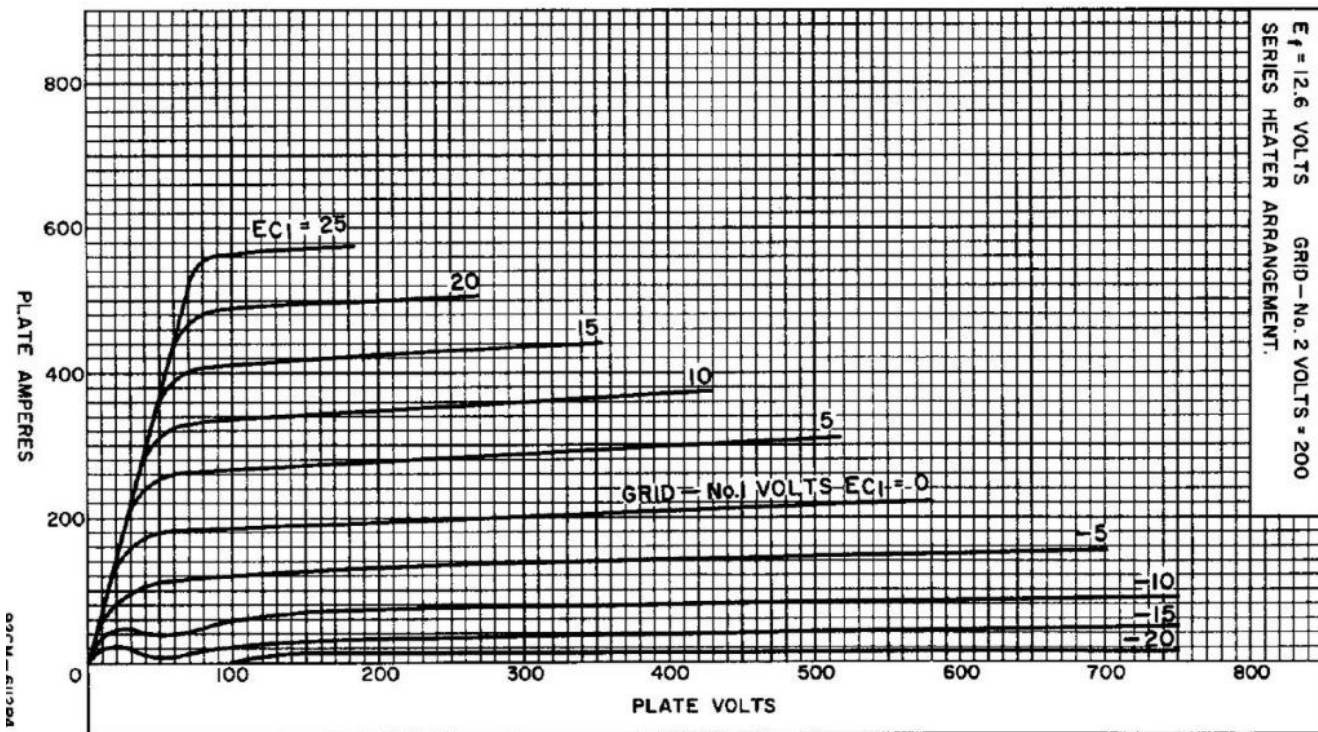
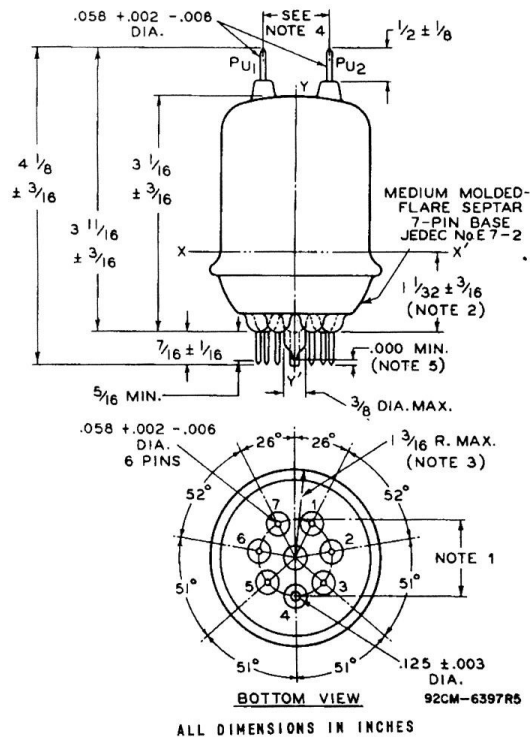

Amplifier design:

Reviewing the data sheet for the 829B (available online, naturally), I refreshed my memory of its characteristics. It is capable of over 90W

output, up to the low VHF frequency range, depending on operating class, plate and screen voltages, and drive power. I decided to run it push-pull, with a link-coupled tuned output and link-coupled tuned input. Less than 2 watts of drive should get 75W or more output, for a power gain of 75X (19 dB). For convenience (and nostalgia), I decided to mount the 829B horizontally, on a plywood base. Push-pull operation lends itself nicely to ground-less construction, since (at least ideally), there is no need for a ground return anywhere, and no real need for shielding of the amplifier for HF. I initially decided to run it biased just at cutoff in Class B. This eliminates any need for a screen clamp circuit, which would be necessary if all the bias were to be obtained by a grid-leak resistor alone. (Remember those heat-producing screen clamp tubes and big series screen power resistors?).

It is interesting that the 829B has a built-in low value (~65pF) capacitor from screen to cathode, no doubt intended as a low-inductance VHF screen bypass. For HF, of course, a larger value capacitor is needed externally. I have read somewhere that the 829B also has built in cross-neutralizing capacitors but there is no reference to this in the data sheet.

The plate characteristic curves show that it has the typical smooth curves and nearly no "kink" at low plate voltages, typical for beam-power pentodes wherein beam-forming plates minimize secondary emission from the plate by compressing electron flow into 'sheets' within the tube. Secondary emission is responsible for the negative-resistance kink on the plate characteristics of all true tetrodes. Beam-forming plates virtually eliminated the use of tetrodes in most power applications.

To cut off the tubes to within a very few milliamperes of plate current, some static testing revealed that about -33V of negative grid bias is required, at least for the tubes that I have. Thus, for about 180 degrees of plate conduction (Class B operation), the grids must swing up from far below cutoff to whatever positive level is required for 180 degrees of plate conduction, thus each section of the tube draws some grid current on alternate halves of the push-pull RF drive. I decided to wait until I could test the amplifier with my intended driver, and then optimize the biasing (and hence the class of operation) for whatever drive power I could conveniently provide. Linearity and IMD is not a concern with CW operation, of course. If there is enough drive available, Class C operation is the most efficient.

A link-coupled tuned push-pull input transformer boosts the driver's pk-pk voltage swing from about 20V up to 120V p-p or more, on each of the 829B's grids. Fixed bias for class B operation is obtained from a 32V Zener diode, biased rather heavily from the 48V bias supply with a 510 ohm resistor. This results in about 30mA of current into the Zener. This is to allow for up to 20mA or so of grid current to be drawn, in case it was desired to operate Class C. The grid current works in opposition to the

Zener diode's current, so more than 20mA must be drawn by the Zener, to prevent it from being turned OFF (back biased) by the grid current. 30mA provides some additional margin for this. A 1K grid-leak resistor in series with the Zener bias to the grid provides about -20V of additional grid leak developed grid voltage, resulting in approximately -50V total DC grid voltage, at 20mA of grid current if enough drive is supplied applied to operate Class C. It is interesting to note that in the 1944 edition of the Radio Amateur's Handbook, all of these things regarding ways of developing tube bias by combination of fixed and grid-leak bias, is thoroughly discussed (without mention of Zener diodes, of course).

For push-pull operation, a tuned, balanced output tank circuit is required. I used 14 gauge enameled wire from the junkbox and wound the tank inductor in two sections, using a 1-3/4" O.D. PVC plastic pipe coupling as a form. Then I removed the form. (I have also tried using two Amidon T100-6 iron powder toroidal cores, 1-inch in diameter, stacked together for the inductor's core. This worked, but somehow I like the looks of the large air-core coils better :o)). The required inductance is relatively high, since the plate impedance of pentodes is always high. The plate impedance to be matched to a 50 ohm load using the output tank and link coupling, can be calculated from the relation for a tube operating in Class B as follows (from any older version of the ARRL Handbook):

$$\text{Plate load } R_1 = \text{Plate voltage} / 1.57 * \text{DC plate mA.}$$

Assuming a loaded plate current of 200mA and plate voltage of 625V, the plate load is then $625 / (1.57 * .200) = 2000$ ohms. Now, this would be the plate load using the two tube sections *in parallel*. But we are using push-pull, so the plate-to-plate load impedance is four times the above, or approximately **8000 ohms**.

With an inductance of about 22uH, this makes the reactance 968 ohms at 7 MHz. If the unloaded Q is about 100, the parallel equivalent resistance of the resonant tank itself is about 97K ohms. (This is much higher than the 829B's desired plate-to-plate load resistance of 8000 ohms, so the resonant tank itself will not load the tube). The swinging output coupling link was somewhat arbitrarily set at six turns, using the same diameter as the tank coils, but using triple-insulated wire due to its proximity to the tank, which carries the DC plate voltage. (There is a shunt RF choke across the link output to ground, just in case a short were to develop between the movable link and the tank circuit). The output link is adjustable in position inside the split output tank coils, and is also series-tuned to near resonance with the series-connected output variable capacitor. Thus, the turns count on the output link is not very critical and there is plenty of range for adjusting the loading to the desired level. This is one of the nice things I had forgotten about regarding swinging, tuned-link coupling.

The grid inputs are tuned, using a compression trimmer across a small link-coupled iron cored bifilar-wound transformer. The grid circuit can be loaded resistively to provide a reasonable match (high return loss) for the driver stage, if desired. Unlike wideband solid-state amplifiers, with which I have some familiarity, there is no negative feedback required for linearity or stability. (Ah, the nearly unilateral properties of multi-grid vacuum tubes are very nice indeed, along with the ease of cooling and the relatively high impedances involved. But alas, very difficult to make broadband as is done with solid state devices. Each technology has its virtues).

Provision for neutralization is made, using two 14 gauge enameled wires, crossing over the socket and going through insulated holes in the socket mounting plate, to the vicinity of the plates of the 829B. Neutralization is verified by applying RF drive to the output link, with filaments lit but no high voltages applied, and observing the signal at the input link, as the output tank is tuned through resonance. The neutralizing wires are bent toward or away from the plates, until there is little or no effect seen in the grid circuit as the plate tank is tuned through resonance. This process, too, is well described in the 1944 Handbook.

Switching Power Supply:

The power supply is a completely different concept than the amplifier itself, in terms of the technology used. Not having an appropriate "60-Hz iron" transformer in the junk box, and just for fun (and to be, let us say, somewhat eclectic), I decided to try my hand at building a switching power supply using modern components. What is required is about 600V plate at 200 mA, 210V screen at about 20 mA, and 12.6V filament at about 1.25A. The transformer's 12.6V Pk-Pk square wave filament voltage is also full-wave rectified and filtered to provide 10-12 VDC at 300 mA for the mosfet driver stage (described later).

Theory of operation:

I decided to use an H-bridge open-loop (ie, nonregulated) architecture, which runs off of the rectified and filtered 120 VAC line voltage, for simplicity. An Amidon ferrite cup core and bobbin were available in the junk box, and it turned out to be just the size needed. The required windings filled the bobbin, thus maximizing the use of the available core area.

I chose to run the supply at 55 KHz, which is a compromise between the mosfet switches' switching times, and transformer core area and core losses. The higher the frequency, the smaller the core cross-sectional area and volume required, but also the higher the core and switching losses become. The four secondaries of the power transformer have turns ratios with the primary such that they provide 55 KHz square wave voltages which when rectified by diode bridge rectifiers with capacitor-input

filters, provide the plate, screen, bias, and filament voltages required by the 829B push-pull amplifier tube.

Refer to the following simplified schematic diagram. The 120V AC line voltage is filtered via an in-line surplus EMI filter, then rectified, providing about 165VDC. The AC line also powers a small 2.4VA transformer which provides a 13VDC low current supply to power the UC3825B pulse width modulator chip, used here to simply generate a 55 KHz square wave of nearly 100 percent duty cycle, of +/- 13V. This square wave output is applied to a small transformer consisting of five windings. The four identical secondary windings provide an electrically-isolated +/- 10V square wave drive voltage to each of four N-channel mosfet gates. These four devices are connected as an H-bridge (so called because the topology resembles the letter H). Note the phasing dots on the four secondary windings (refer to the simplified schematic, following). These are arranged for driving only the two *diagonal* fets ON, during one half cycle of the 55 KHz square wave. This pair is then turned off, *before* the other diagonal pair are turned on. This alternates with each half cycle of the 55 KHz square wave. The H-bridge's function is conceptually quite simple, see the following simplified schematic diagram. The load is placed across the center arms of the bridge, and when each diagonally opposite pair of switches are enabled, then 165V is applied to one end of the power transformer's primary and the other end is connected to the 165 volt negative return. During the next half cycle, the opposite diagonal pair of switches are enabled, applying 165V to the opposite end of the primary, with the other end now returned to negative. This effectively places a reversing 330V peak-to-peak 55 KHz square wave across the primary. It is absolutely essential that the mosfets making up the two *vertical* paths across the 165V supply, never be enabled at the same time. That is, there must never be any *overlap* in the turn-on and turn-off of these mosfets. That would place a direct short across the 165VDC supply, instantly destroying the mosfets (sometimes in spectacular fashion). One of the characteristics of switching power supplies is that, due to the relatively large amounts of energy storage involved, circuit failures can result in large currents, and very high instantaneous component power dissipations.

The source of power for the H-bridge is a direct connection to the AC line, so the H-bridge and all circuits connected with the primary must be isolated from ground so that the AC line plug can be inserted either way into an outlet without catastrophic or dangerous results. This is accomplished by using transformer drive to the four mosfet gates in the H-bridge. The secondary windings of the gate drive transformer, and the primary winding of the power transformer, isolate the power transformer secondary ground-referenced outputs electrically (but not magnetically!) from the H-bridge circuit.

For the power transformer, I used ordinary formvar-insulated ("enameled") wire for the primary winding, but I also enclosed this primary winding in a Kapton taped layer, which has over 2KV of insulation capability. I also used Teflon sleeving on the primary and 650V secondary leads where they exit the bobbin and core. For the gate drive transformer primary, I used Teflon-insulated wire for the primary, for good high voltage AC line isolation. There is thus no need for a large 60-Hz transformer, as all of the output power is provided at a frequency of 55 KHz instead. At this frequency, the 200W power transformer need only be about the size of an egg, which is one of the major advantages of switching power supplies over ones powered entirely by the 60 Hz mains frequency. The price paid for this is, of course, greater circuit complexity and higher component count than required by the classic 60Hz transformer/rectifier/filter circuit. A major complication also is the absolute requirement for EMI filtering of the AC line input, for both common-mode and differential-mode noise sources within the supply. The sharp-edged repetitive waveforms in switching supplies are rich in harmonics, in both the electrical and magnetic fields generated by the switching supply. I used a sealed EMI filter salvaged from some old equipment. I can hear no birdies from the supply during normal operation.

See Appendix A for a detailed description of the electrical and mechanical design of the power and gate drive transformers, and Appendix B for LTSpice transient simulation of the startup of the power supply.

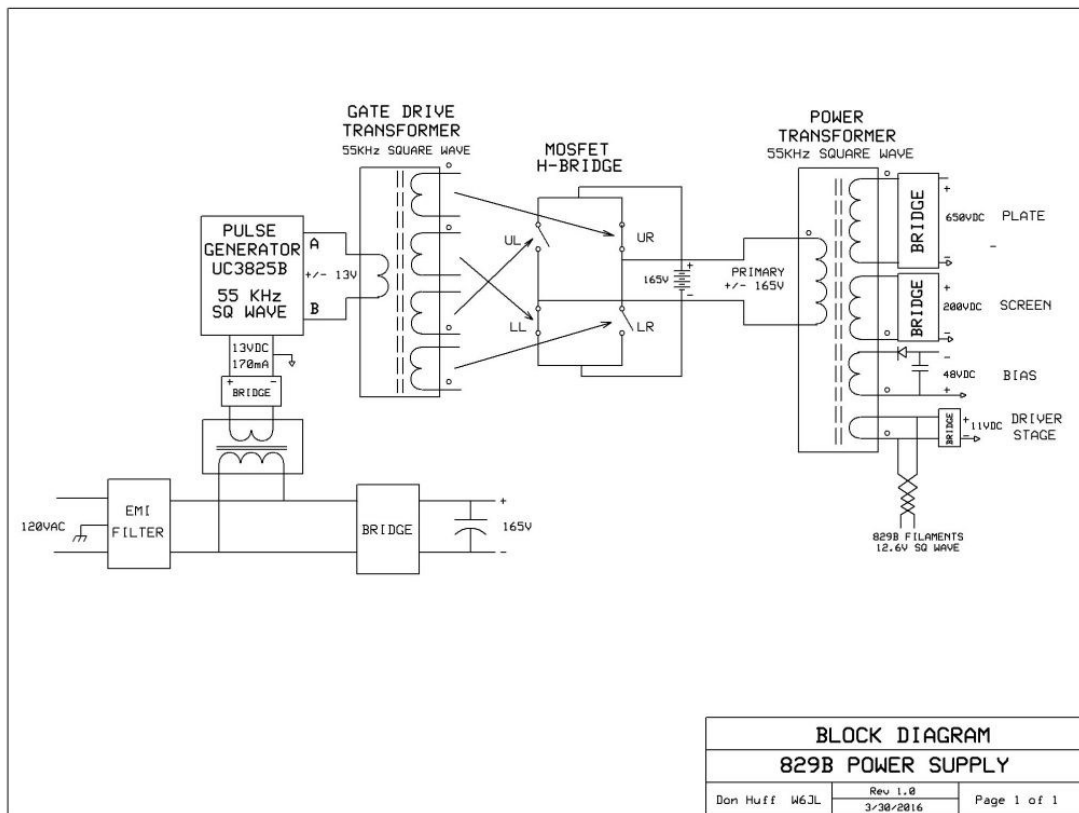

Simplified schematic diagram of the switching power supply

A ground-referenced local 13V supply is needed to run the 55 KHz complementary totem-pole output pulse generator, a UC3825A, which drives the gate drive transformer. Without this local supply, the switcher would never start up, there being no source of ground-referenced DC power to run the pulse generator. This local supply is provided by a small 60-Hz 2.4VA transformer with a 10V output winding, which is rectified and filtered to power the UC3825A. (Yes, the small transformer was also in the junkbox). I would have liked to eliminate the need for this extra supply, but I could not come up with a good workaround for it. Unfortunately the current requirement is relatively high, about 170mA, due to the magnetizing current of the gate driver transformer, and the small current required to charge and discharge the gate capacitances of the four mosfets to achieve fractional uSec switching times. The H-bridge mosfets, Infineon 21N50C3's, dissipate so little power that the four TO-220-packaged mosfets require no heat sinking whatsoever. This simplified things mechanically.

The supply has no output current-limiting, or shutdown circuits. A 2A fuse in series with the H-bridge 165V supply, effectively protects the supply in the event of an output short. I tested this several times (inadvertently :o)).

Always keep in mind that the voltages in a plate supply such as this can be lethal.

The 829B's driver stage.

The 829B requires a driver capable of providing a watt or so of grid drive, depending on the class of operation of the tube. I decided to shoot for class B, so the tube would run close to cutoff bias with no RF drive, and required drive power is reduced, compared with operating Class C. This also eliminated the need a screen clamping circuit to protect the 829B from excessive plate current when there is no drive power (as when keying the driver stage(s)). I decided, since the VFO would be a DDS VFO, to also make the driver broadband, Class A. In the junkbox I found a Mitsubishi RD06HHF1 RF mosfet, which comes in a TO-220 package with tab connected to the source, and hence the source connection is easily grounded, along with any heat sink. This is common with most of today's RF TO-220 devices. This greatly facilitates constructing a common-source RF amplifier, requiring no insulation of the mounting tab to heat sink/ground. With a few dBm of drive from the DDS, and with the driver providing about 20dB gain, this yields up to a watt output into 50 ohms, with 10mW (+10dBm) drive from the VFO. This output is achieved using a class A shunt feedback circuit arrangement, which makes the driver broadband over the HF range, with roughly 50 ohms input and output impedances. Following is a full-page schematic diagram of the power

supply/driver/829B amplifier. Mosfet Q1 in the RD06HHF1's input shunts the input to ground and also disables the DC bias on the RD06HHF1 when the key is up, shutting down the driver stage. This is to suppress any audible signal in the receiver due to leak-through of the continuously-running DDS VFO, which operates on the received signal's frequency. The DC supply for the mosfet driver is obtained from a full-wave bridge rectifier and filter on the 12.6V filament winding. See the following schematic of the entire transmitter, including the driver stage and power supply.

VFO and keyed buffer amplifier:

The VFO is a DDS VFO, which utilizes a Chinese surplus small PC board containing an Analog Devices AD9850 DDS chip and a 125 MHz crystal reference clock oscillator. These modules have been available on EBay at very low prices for quite some time. The AD9850 in this VFO is controlled by an Atmega 328P microcontroller, which was programmed using an Arduino Uno and using a bootloader loaded onto the 328P to download the object code. Learning to program using an Arduino was an interesting learning experience in programming, using Arduino's simplified subset of the "C" programming language, with which even I could do some elementary code writing on my own. I started with an Arduino-based DDS program written by AD7C, and modified it to suit me. I then designed a PC board using a 30-day free evaluation copy of Eagle software to draw the schematic and design the PC board. This program can create the necessary Gerber files needed by commercial PC board manufacturers. I normally make my own PC boards, using photosensitized copper clad to make single-sided (back side solid copper ground plane) boards. But for this project, I tried my first use of a very low-cost commercial Chinese prototype board manufacturer called PCBway. This resulted in a short turnaround time, excellent quality, plated-through, silkscreened and solder-masked board for the DDS VFO/Keyed amp. See schematic and photos below.

Following the DDS VFO, and on the same PC board, is a keyed, broadband class-A feedback amplifier stage using the venerable 2N5109 CATV transistor. This is a design which I have used for a previous transmitter, see <https://www.qrz.com/db/W6JL>

This stage has about 20dB gain. The keying envelope rise and fall times are adjustable using the two pots, R4 and R5. This simple integrator circuit is an easy way to obtain adjustable keying rise and fall times. Below is a full-page schematic of the PC board with combined VFO and keyed buffer amplifier.

Following the VFO schematic, is a full-page schematic of the 829B amplifier, driver, and power supply. Then follows several photographs of the completed VFO, transmitter and power supply.

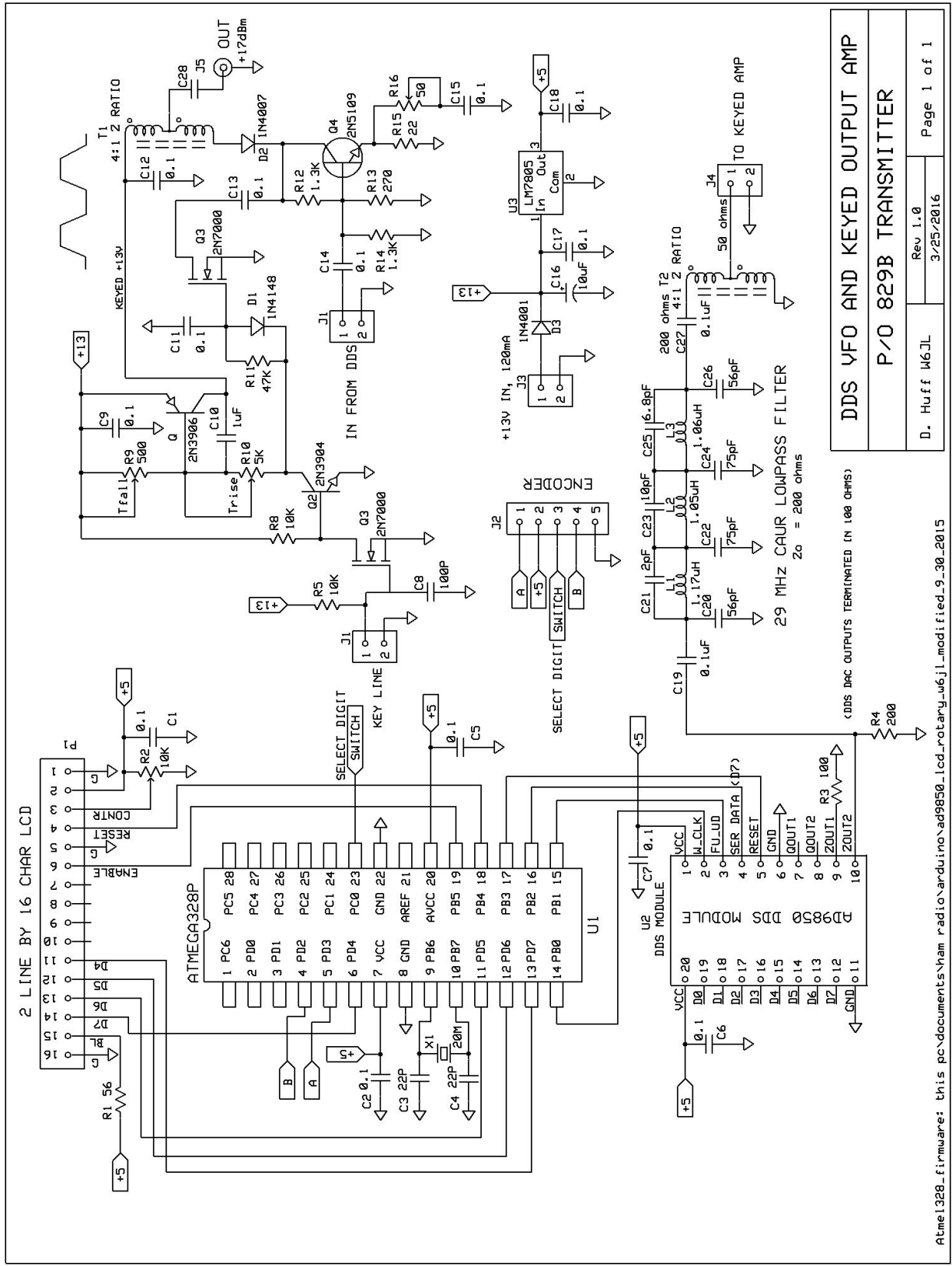

DDS VFO AND KEYED OUTPUT AMP
P/O 829B TRANSMITTER
D. Huff W6JL
Rev 1.0
3/25/2016
Page 1 of 1

Atmel328_firmware: this pc\documents\ham radio\arduino\sd9850_lcd_rotary_w6jl_modified_9_30_2015

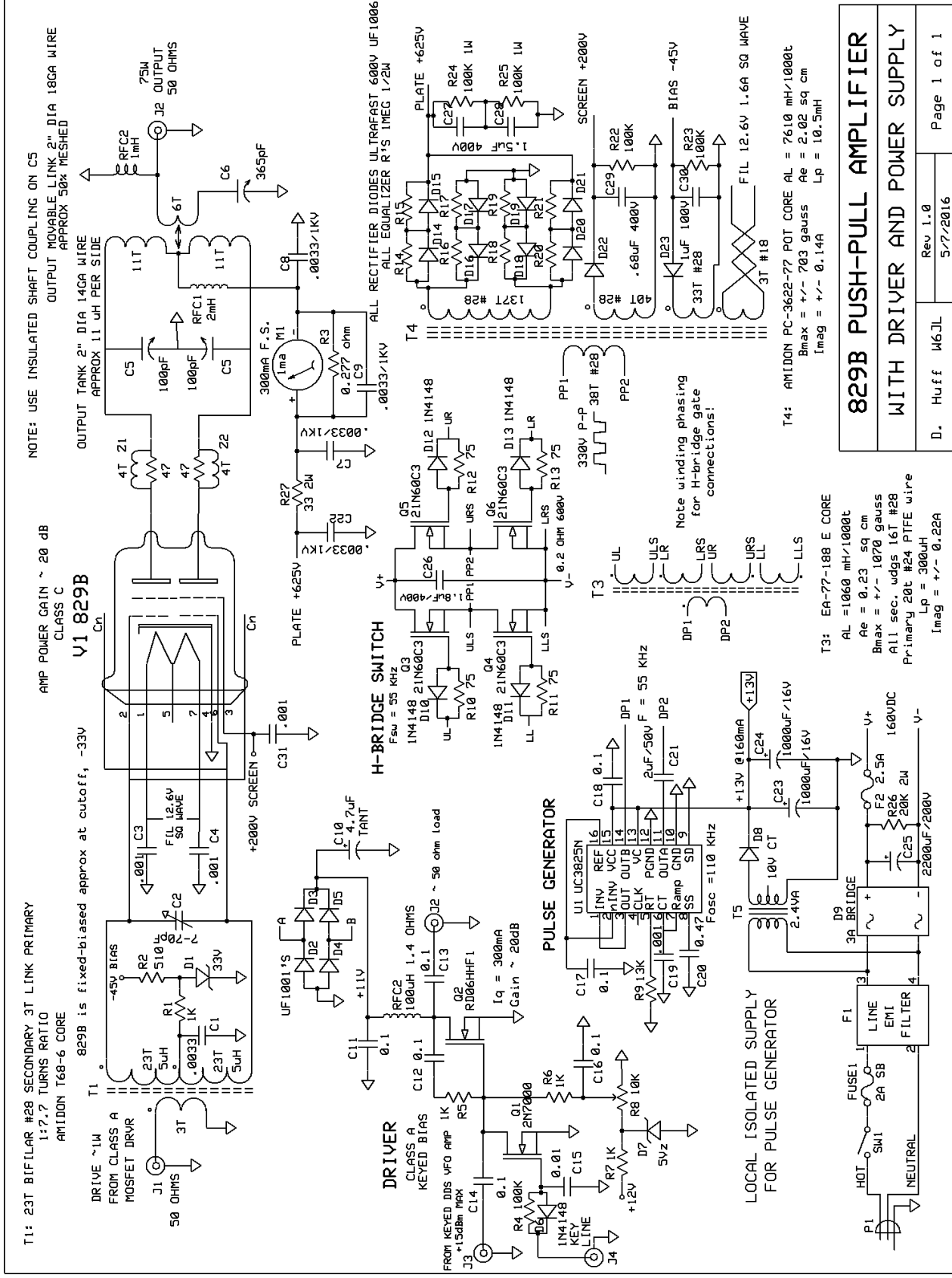

NOTE: USE INSULATED SHAFT COUPLING ON C5
 OUTPUT MOVABLE LINK 2" DIA 18GA WIRE
 APPROX 50% MESHED

AMP POWER GAIN ~ 20 dB
 CLASS C
V1 829B

T1: 23T BIFILAR #28 SECONDARY 3T LINK PRIMARY
 1:7.7 TURNS RATIO
 AMIDON T68-6 CORE

OUTPUT TANK 2" DIA 14GA WIRE
 APPROX 11 uH PER SIDE

829B is fixed-biased approx at cutoff, -33V

DRIVE ~1u
 FROM CLASS A
 MOSFET DRVR

C5 100pF
 RFC1 2mH
 C5 300mA F.S.
 W1
 R3 0.277 ohm
 C9 .0033/1KV

PLATE +625V
 R27 33 2W
 R2 0.033/1K
 R3 0.277 ohm
 C9 .0033/1KV

UF1001'S
 REC2
 C12 0.1
 C13 0.1
 R5 1K
 R4 100K
 R6 1K
 R7 1K
 R8 10K
 R9 13K
 R10 75
 R11 75
 R12 75
 R13 75
 R14 75
 R15 75
 R16 75
 R17 75
 R18 75
 R19 75
 R20 75
 R21 75
 R22 100K
 R23 100K
 R24 100K 1W
 R25 100K 1W
 R26 100K
 R27 33 2W
 R28 330V P-P #28
 R29 .68uF 400V
 R30 100V 100K
 R31 33T #28
 R32 100K
 R33 100K
 R34 100K
 R35 100K
 R36 100K
 R37 100K
 R38 100K
 R39 100K
 R40 100K
 R41 100K
 R42 100K
 R43 100K
 R44 100K
 R45 100K
 R46 100K
 R47 100K
 R48 100K
 R49 100K
 R50 100K
 R51 100K
 R52 100K
 R53 100K
 R54 100K
 R55 100K
 R56 100K
 R57 100K
 R58 100K
 R59 100K
 R60 100K
 R61 100K
 R62 100K
 R63 100K
 R64 100K
 R65 100K
 R66 100K
 R67 100K
 R68 100K
 R69 100K
 R70 100K
 R71 100K
 R72 100K
 R73 100K
 R74 100K
 R75 100K
 R76 100K
 R77 100K
 R78 100K
 R79 100K
 R80 100K
 R81 100K
 R82 100K
 R83 100K
 R84 100K
 R85 100K
 R86 100K
 R87 100K
 R88 100K
 R89 100K
 R90 100K
 R91 100K
 R92 100K
 R93 100K
 R94 100K
 R95 100K
 R96 100K
 R97 100K
 R98 100K
 R99 100K
 R100 100K

C1 5uH
 C2 5uH
 C3 0.001
 C4 0.001
 C5 100pF
 C6 365pF
 C7 1mH
 C8 .0033/1KV
 C9 .0033/1KV
 C10 4.7uF
 C11 0.1
 C12 0.1
 C13 0.1
 C14 0.1
 C15 0.01
 C16 0.1
 C17 0.1
 C18 0.1
 C19 100pF
 C20 0.47
 C21 1000uF/16V
 C22 1000uF/16V
 C23 1000uF/16V
 C24 1000uF/16V
 C25 2200uF/200V
 C26 1000uF/16V
 C27 1000uF/16V
 C28 1000uF/16V
 C29 .68uF 400V
 C30 100V 100K
 C31 0.001

Q1 2N7000
 Q2 R066HF1
 Q3 IN4148 2.1N60C3
 Q4 IN4148 2.1N60C3
 Q5 IN4148 2.1N60C3
 Q6 IN4148 2.1N60C3
 Q7 300mA F.S.
 W1

D1 33V
 D2 33V
 D3 UF1001'S
 D4 UF1001'S
 D5 UF1001'S
 D6 10V CT
 D7 5VZ
 D8 10V CT
 D9 3A BRIDGE
 D10 IN4148
 D11 IN4148
 D12 IN4148
 D13 IN4148
 D14 IN4148
 D15 IN4148
 D16 IN4148
 D17 IN4148
 D18 IN4148
 D19 IN4148
 D20 IN4148
 D21 IN4148
 D22 IN4148
 D23 33T #28
 D24 33T #28
 D25 33T #28
 D26 33T #28
 D27 33T #28
 D28 33T #28
 D29 33T #28
 D30 33T #28
 D31 33T #28
 D32 33T #28
 D33 33T #28
 D34 33T #28
 D35 33T #28
 D36 33T #28
 D37 33T #28
 D38 33T #28
 D39 33T #28
 D40 33T #28
 D41 33T #28
 D42 33T #28
 D43 33T #28
 D44 33T #28
 D45 33T #28
 D46 33T #28
 D47 33T #28
 D48 33T #28
 D49 33T #28
 D50 33T #28
 D51 33T #28
 D52 33T #28
 D53 33T #28
 D54 33T #28
 D55 33T #28
 D56 33T #28
 D57 33T #28
 D58 33T #28
 D59 33T #28
 D60 33T #28
 D61 33T #28
 D62 33T #28
 D63 33T #28
 D64 33T #28
 D65 33T #28
 D66 33T #28
 D67 33T #28
 D68 33T #28
 D69 33T #28
 D70 33T #28
 D71 33T #28
 D72 33T #28
 D73 33T #28
 D74 33T #28
 D75 33T #28
 D76 33T #28
 D77 33T #28
 D78 33T #28
 D79 33T #28
 D80 33T #28
 D81 33T #28
 D82 33T #28
 D83 33T #28
 D84 33T #28
 D85 33T #28
 D86 33T #28
 D87 33T #28
 D88 33T #28
 D89 33T #28
 D90 33T #28
 D91 33T #28
 D92 33T #28
 D93 33T #28
 D94 33T #28
 D95 33T #28
 D96 33T #28
 D97 33T #28
 D98 33T #28
 D99 33T #28
 D100 33T #28

T1: 23T BIFILAR #28 SECONDARY 3T LINK PRIMARY
 1:7.7 TURNS RATIO
 AMIDON T68-6 CORE

T4: AMIDON PC-3622-77 POT CORE
 AL = 7610 mH/1000t
 Bmax = +/- 703 gauss
 Ae = 2.02 sq cm
 Lp = +/- 0.14A
 Imag = +/- 0.14A

T3: EA-77-188 E CORE
 AL = 1060 mH/1000t
 Ae = 0.23 sq cm
 Bmax = +/- 1070 gauss
 All sec. wds 16T #28
 Primary 20T #24 PIFE wire
 Lp = 300uH
 Imag = +/- 0.22A

H-BRIDGE SWITCH
 Fsw = 55 KHz

PULSE GENERATOR
 Fosc = 110 KHz

LOCAL ISOLATED SUPPLY
 FOR PULSE GENERATOR

ALL RECTIFIER DIODES ULTRAFEAST 600V UF1006
 ALL EQUALIZER R'S 1MEG 1.2W

PLATE +625V
 SCREEN +200V

BIAS -45V
 FIL 12.6V 1.6A SQ WAVE

829B is fixed-biased approx at cutoff, -33V

DRIVE ~1u
 FROM CLASS A
 MOSFET DRVR

AMP POWER GAIN ~ 20 dB
 CLASS C
V1 829B

DRIVER
 CLASS A
 KEYED BIAS

LOCAL ISOLATED SUPPLY
 FOR PULSE GENERATOR

OUTPUT TANK 2" DIA 14GA WIRE
 APPROX 11 uH PER SIDE

829B is fixed-biased approx at cutoff, -33V

DRIVER
 CLASS A
 KEYED BIAS

LOCAL ISOLATED SUPPLY
 FOR PULSE GENERATOR

NOTE: USE INSULATED SHAFT COUPLING ON C5
 OUTPUT MOVABLE LINK 2" DIA 18GA WIRE
 APPROX 50% MESHED

AMP POWER GAIN ~ 20 dB
 CLASS C
V1 829B

DRIVER
 CLASS A
 KEYED BIAS

LOCAL ISOLATED SUPPLY
 FOR PULSE GENERATOR

OUTPUT TANK 2" DIA 14GA WIRE
 APPROX 11 uH PER SIDE

829B is fixed-biased approx at cutoff, -33V

DRIVER
 CLASS A
 KEYED BIAS

LOCAL ISOLATED SUPPLY
 FOR PULSE GENERATOR

NOTE: USE INSULATED SHAFT COUPLING ON C5
 OUTPUT MOVABLE LINK 2" DIA 18GA WIRE
 APPROX 50% MESHED

AMP POWER GAIN ~ 20 dB
 CLASS C
V1 829B

DRIVER
 CLASS A
 KEYED BIAS

LOCAL ISOLATED SUPPLY
 FOR PULSE GENERATOR

OUTPUT TANK 2" DIA 14GA WIRE
 APPROX 11 uH PER SIDE

829B is fixed-biased approx at cutoff, -33V

DRIVER
 CLASS A
 KEYED BIAS

LOCAL ISOLATED SUPPLY
 FOR PULSE GENERATOR

NOTE: USE INSULATED SHAFT COUPLING ON C5
 OUTPUT MOVABLE LINK 2" DIA 18GA WIRE
 APPROX 50% MESHED

AMP POWER GAIN ~ 20 dB
 CLASS C
V1 829B

DRIVER
 CLASS A
 KEYED BIAS

LOCAL ISOLATED SUPPLY
 FOR PULSE GENERATOR

OUTPUT TANK 2" DIA 14GA WIRE
 APPROX 11 uH PER SIDE

829B is fixed-biased approx at cutoff, -33V

DRIVER
 CLASS A
 KEYED BIAS

LOCAL ISOLATED SUPPLY
 FOR PULSE GENERATOR

NOTE: USE INSULATED SHAFT COUPLING ON C5
 OUTPUT MOVABLE LINK 2" DIA 18GA WIRE
 APPROX 50% MESHED

AMP POWER GAIN ~ 20 dB
 CLASS C
V1 829B

DRIVER
 CLASS A
 KEYED BIAS

LOCAL ISOLATED SUPPLY
 FOR PULSE GENERATOR

OUTPUT TANK 2" DIA 14GA WIRE
 APPROX 11 uH PER SIDE

829B is fixed-biased approx at cutoff, -33V

DRIVER
 CLASS A
 KEYED BIAS

LOCAL ISOLATED SUPPLY
 FOR PULSE GENERATOR

NOTE: USE INSULATED SHAFT COUPLING ON C5
 OUTPUT MOVABLE LINK 2" DIA 18GA WIRE
 APPROX 50% MESHED

AMP POWER GAIN ~ 20 dB
 CLASS C
V1 829B

DRIVER
 CLASS A
 KEYED BIAS

LOCAL ISOLATED SUPPLY
 FOR PULSE GENERATOR

OUTPUT TANK 2" DIA 14GA WIRE
 APPROX 11 uH PER SIDE

829B is fixed-biased approx at cutoff, -33V

DRIVER
 CLASS A
 KEYED BIAS

LOCAL ISOLATED SUPPLY
 FOR PULSE GENERATOR

NOTE: USE INSULATED SHAFT COUPLING ON C5
 OUTPUT MOVABLE LINK 2" DIA 18GA WIRE
 APPROX 50% MESHED

AMP POWER GAIN ~ 20 dB
 CLASS C
V1 829B

DRIVER
 CLASS A
 KEYED BIAS

LOCAL ISOLATED SUPPLY
 FOR PULSE GENERATOR

OUTPUT TANK 2" DIA 14GA WIRE
 APPROX 11 uH PER SIDE

829B is fixed-biased approx at cutoff, -33V

DRIVER
 CLASS A
 KEYED BIAS

LOCAL ISOLATED SUPPLY
 FOR PULSE GENERATOR

NOTE: USE INSULATED SHAFT COUPLING ON C5
 OUTPUT MOVABLE LINK 2" DIA 18GA WIRE
 APPROX 50% MESHED

AMP POWER GAIN ~ 20 dB
 CLASS C
V1 829B

DRIVER
 CLASS A
 KEYED BIAS

LOCAL ISOLATED SUPPLY
 FOR PULSE GENERATOR

OUTPUT TANK 2" DIA 14GA WIRE
 APPROX 11 uH PER SIDE

829B is fixed-biased approx at cutoff, -33V

DRIVER
 CLASS A
 KEYED BIAS

LOCAL ISOLATED SUPPLY
 FOR PULSE GENERATOR

NOTE: USE INSULATED SHAFT COUPLING ON C5
 OUTPUT MOVABLE LINK 2" DIA 18GA WIRE
 APPROX 50% MESHED

AMP POWER GAIN ~ 20 dB
 CLASS C
V1 829B

DRIVER
 CLASS A
 KEYED BIAS

LOCAL ISOLATED SUPPLY
 FOR PULSE GENERATOR

OUTPUT TANK 2" DIA 14GA WIRE
 APPROX 11 uH PER SIDE

829B is fixed-biased approx at cutoff, -33V

DRIVER
 CLASS A
 KEYED BIAS

LOCAL ISOLATED SUPPLY
 FOR PULSE GENERATOR

NOTE: USE INSULATED SHAFT COUPLING ON C5
 OUTPUT MOVABLE LINK 2" DIA 18GA WIRE
 APPROX 50% MESHED

AMP POWER GAIN ~ 20 dB
 CLASS C
V1 829B

DRIVER
 CLASS A
 KEYED BIAS

LOCAL ISOLATED SUPPLY
 FOR PULSE GENERATOR

OUTPUT TANK 2" DIA 14GA WIRE
 APPROX 11 uH PER SIDE

829B is fixed-biased approx at cutoff, -33V

DRIVER
 CLASS A
 KEYED BIAS

LOCAL ISOLATED SUPPLY
 FOR PULSE GENERATOR

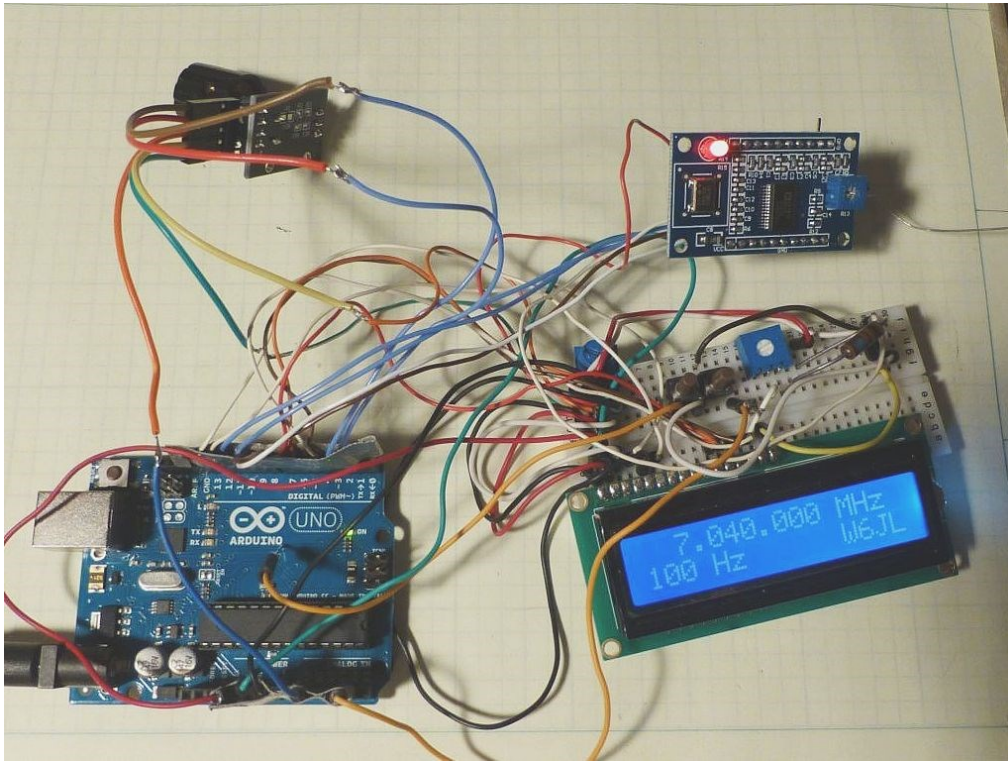

Above, bread-boarded DDS VFO using an Arduino Uno for firmware development, with Chinese surplus DDS module at upper right. Below, completed VFO/Keyed amp PC board with DDS module mounted.

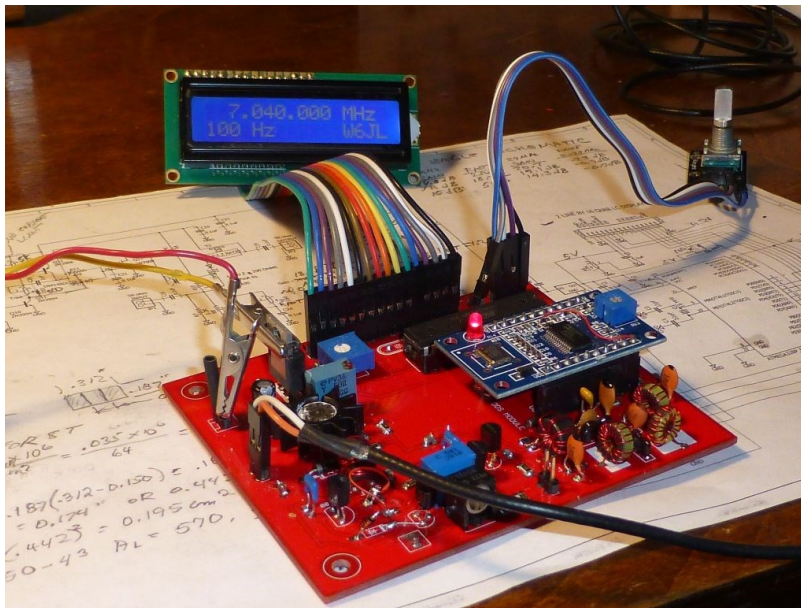

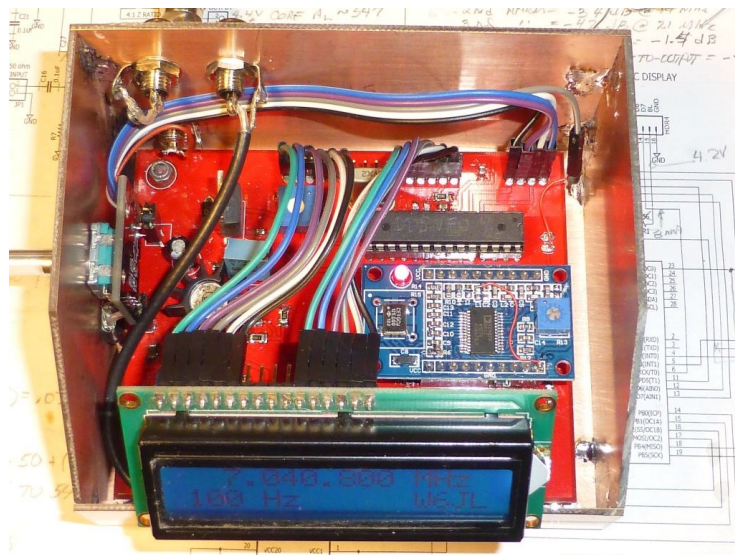

Above, interior of enclosed Atmel328P controlled DDS VFO with keyed class A buffer amp, and the Chinese surplus AD9850 DDS VFO board (blue). The tuning is via an inexpensive rotary encoder, also sourced from China. Pictured below is the enclosed VFO. The LCD display is a 16x2 module, costing less than \$5.00. Copper-clad makes a simple shielded enclosure.



Operation and Performance:

After getting the DDS VFO, power supply, and driver stage working, an initial static setup was made to verify that the 829B was at least

operating reasonably well. After all, the tube has sat unused in its aging cardboard container for over 70 years, probably. Initial checks were made with the filament driven from a 12.6V DC power source. Filaments looked good. Then the power supply was turned on and DC voltages checked, with -55V bias applied to the 829's grids to keep it cut off. Plate voltage tends to soar with the very lightly loaded switching supply, to about 725V, with 250V on the screens. As bias was reduced the tube began to draw significant current. At about 0V bias, the plate current was nearly 200mA, so this condition could not be held but a second or two, due to rapid heating of the plates (starting to show color). So the tube appeared to be in reasonable shape.

Then, RF drive was initially applied using a signal generator to drive the mosfet driver stage. Some experimenting with the grid circuit revealed that more drive was available if the push-pull grid circuit was tuned. A 3-turn link was found to provide the most drive at resonance. (Grid bias is applied to the RF bypassed transformer center tap). This resulted in best drive efficiency. Biased for about 5mA of quiescent plate current (829B is barely turned on), maximum output power on 7 MHz about 75-80 watts (+49 dBm) with the voltages available under load from the switching supply. This is with a plate current of about 200Ma and grid current of 15mA. The DC voltage to the driver drops to about 10.5 VDC under load, which reduces the drive level somewhat. This DC voltage is obtained via a full wave bridge rectifier from the filament winding. It might be better to obtain this voltage from an additional 4 turn bifilar winding on the power transformer, if space is available. This could be full wave rectified and filtered to supply the mosfet driver stage with higher DC voltage which would increase output power.

All in all, the rig makes a fun little transmitter to use, and even more interesting because it encompasses technology covering a period of over 70 years. The venerable 829B amplifier tube makes a very useful CW QSK rig today, in the 21st century. I have no doubt that 58 years from now there will still be 829B's around, hopefully with some in use.

829B amplifier

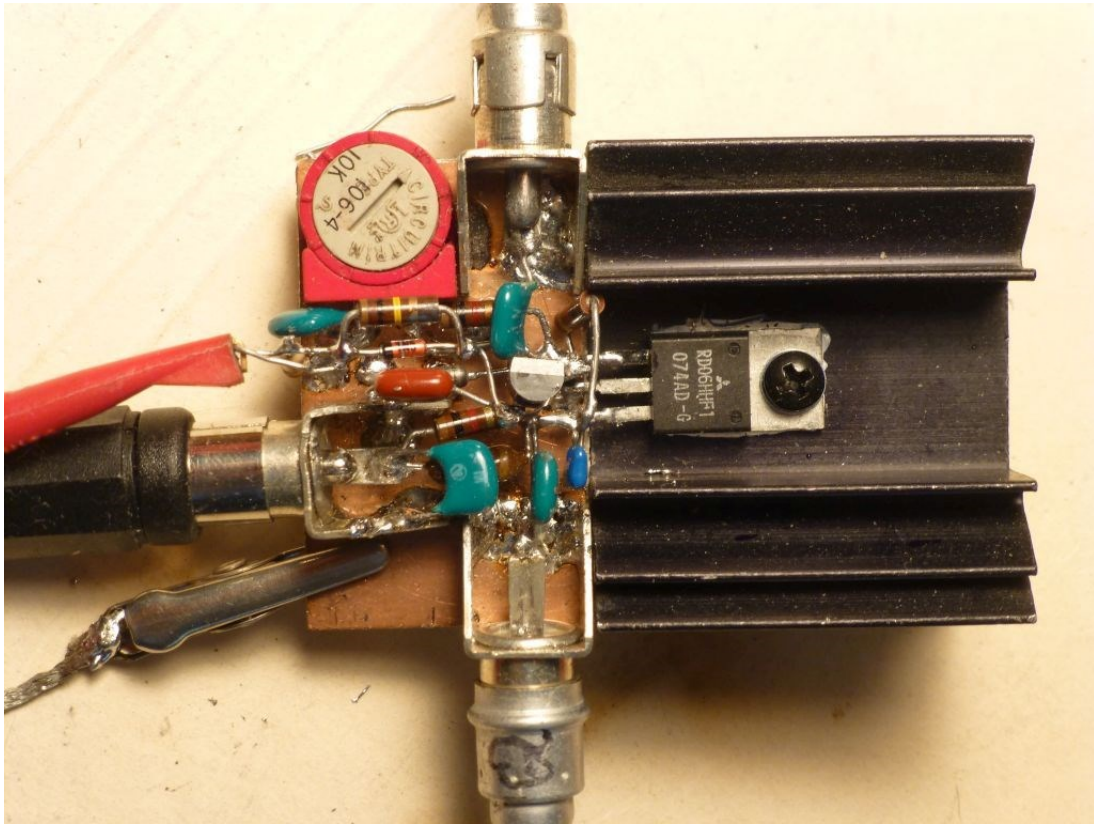

RD06HHF1 mosfet broadband driver stage

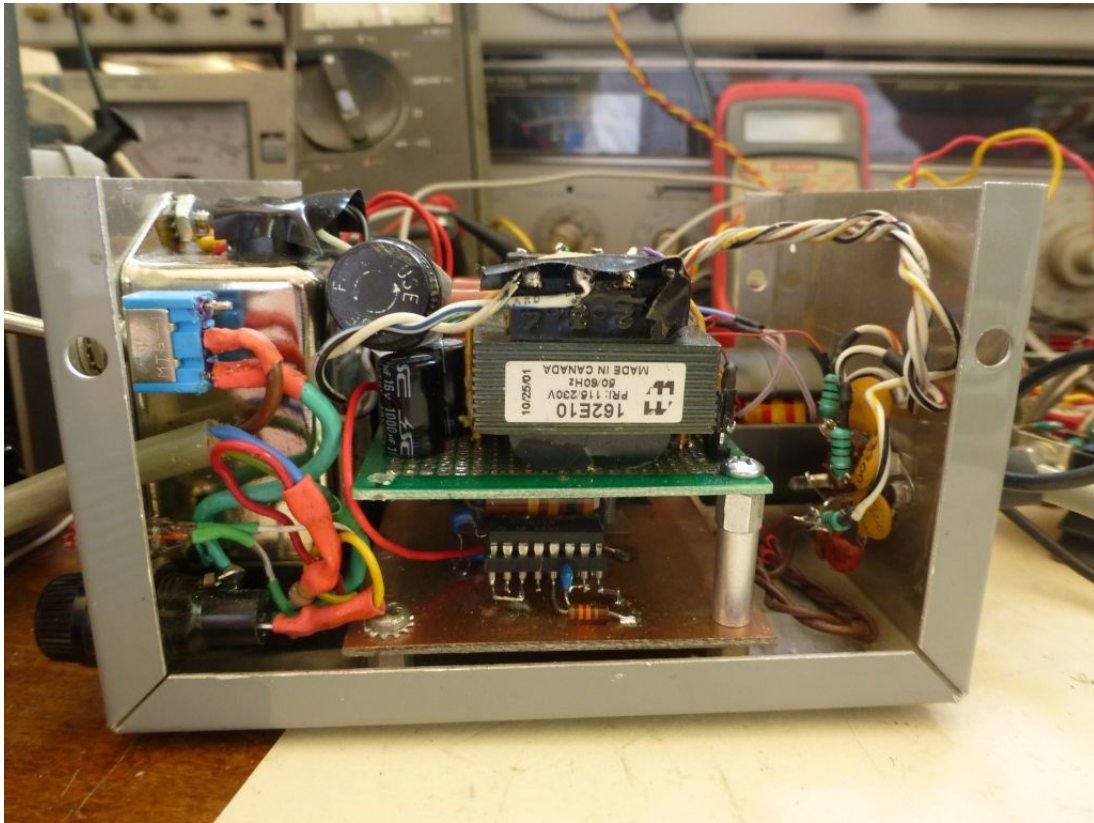

Off-line switching power supply, running at 55 KHz, supplies 650V plate, 200V screen, 12.6V filament, and -45V bias

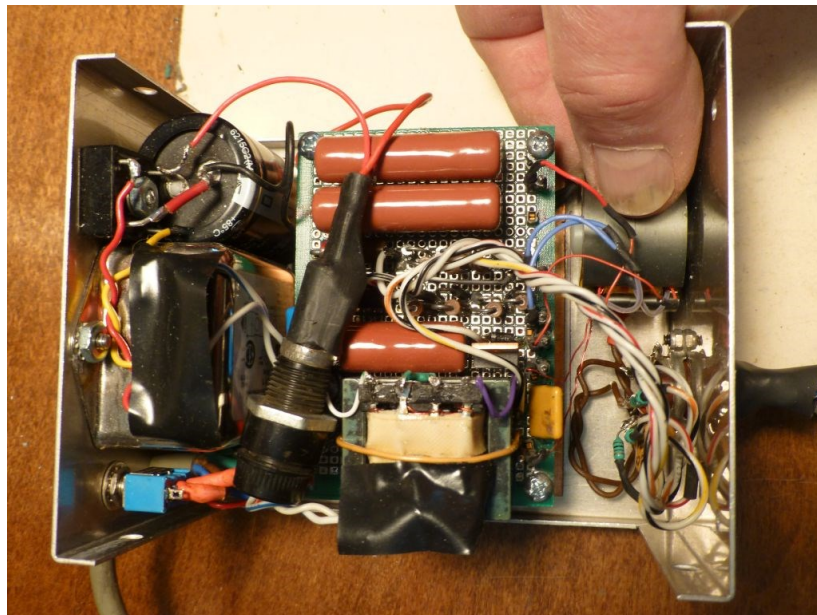

ABOVE: Illustrating the small size of the 200+ watt power transformer in the switching power supply. By contrast, the 60 Hz local supply transformer at bottom center is rated at 2.4W.

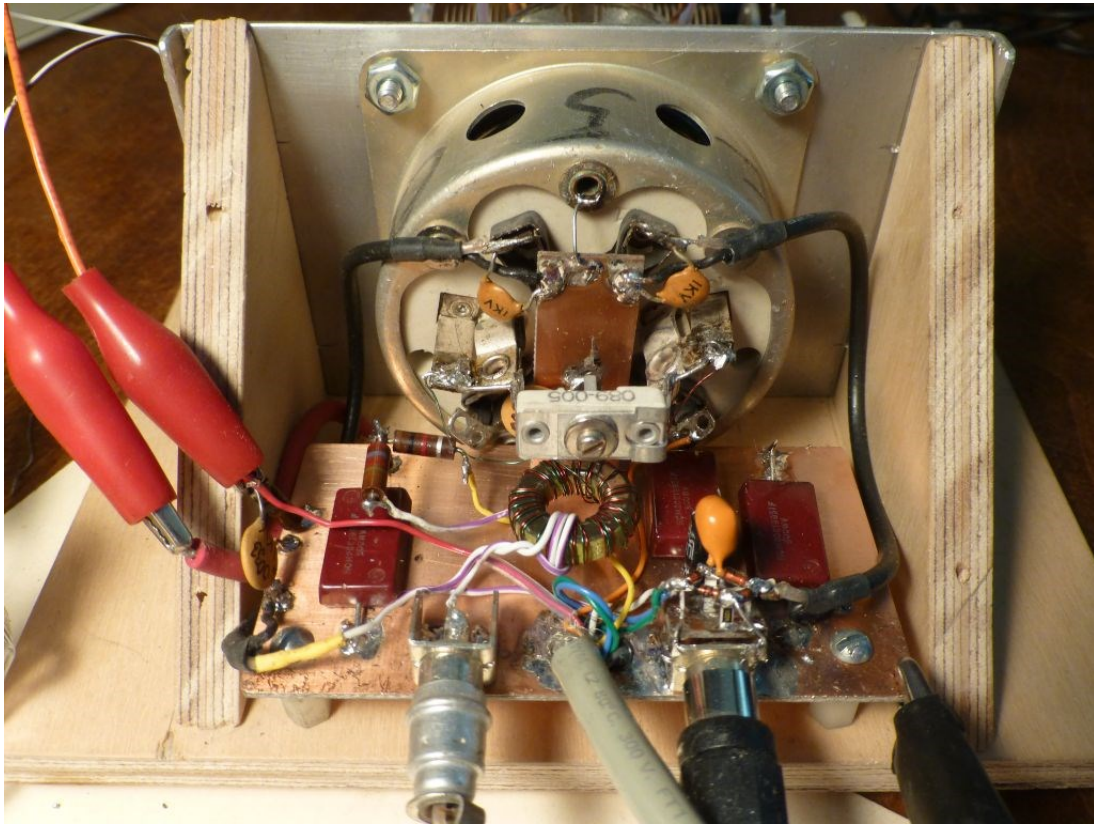

829B's grid circuit, built ugly-style on a scrap of copperclad.

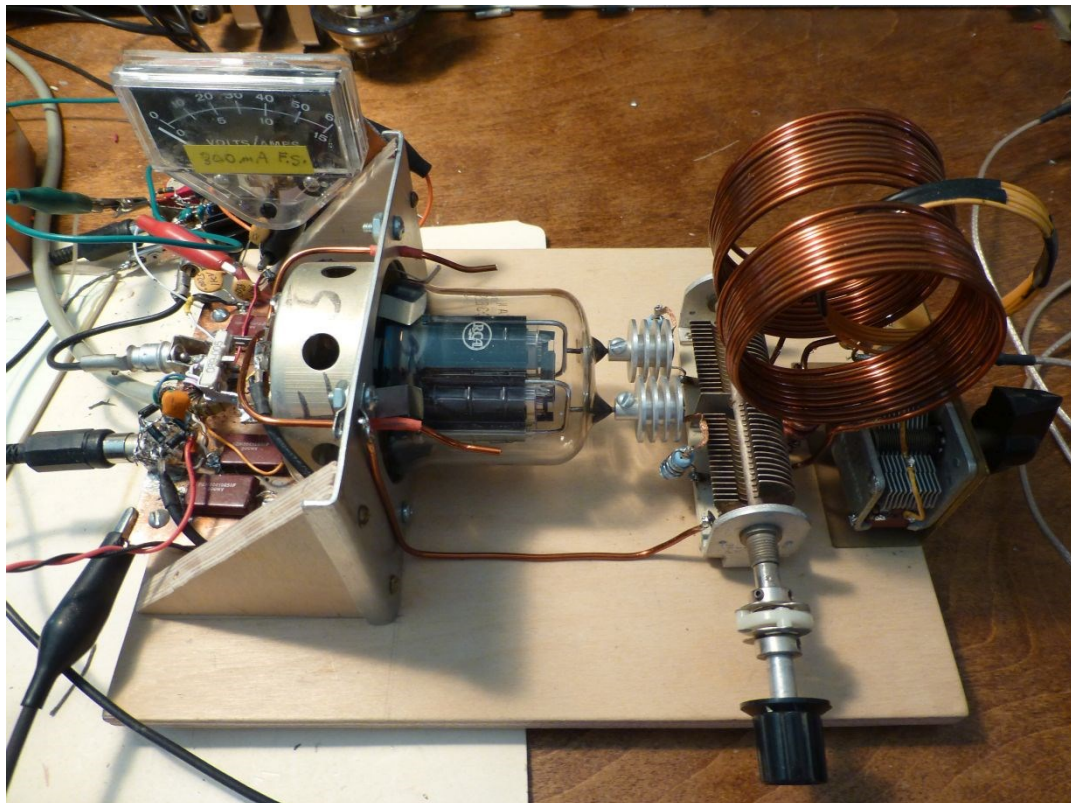

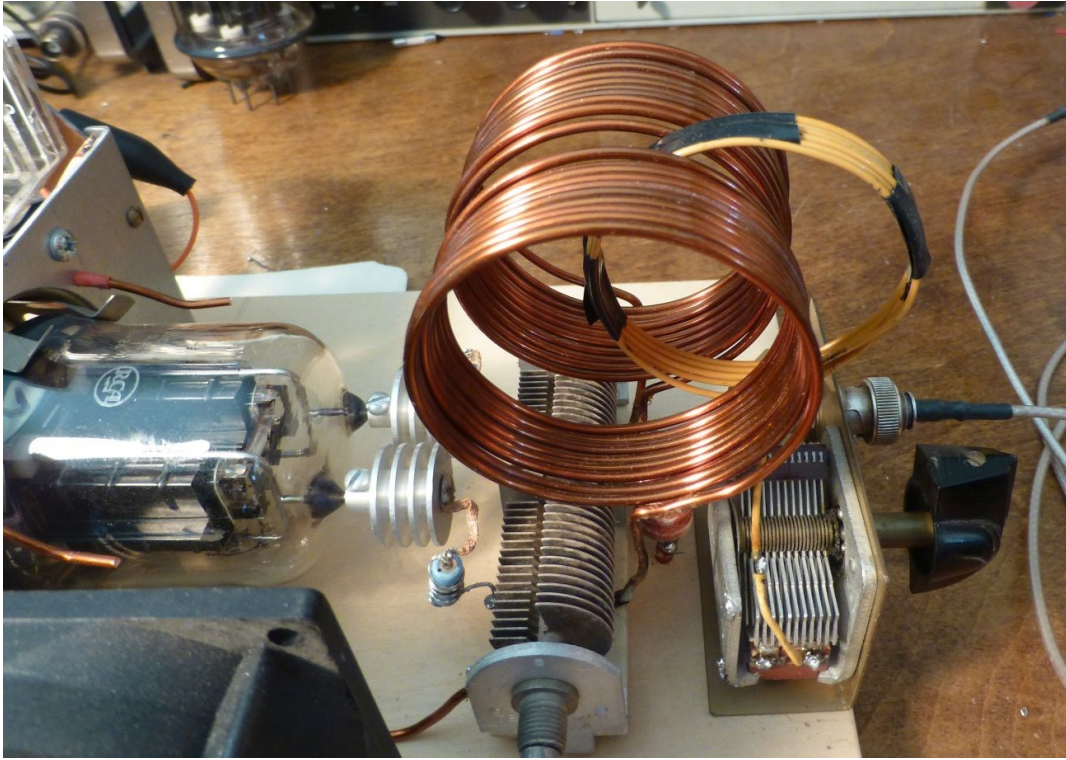

Loose coupled output movable tuned link. Set for maximum Pout.

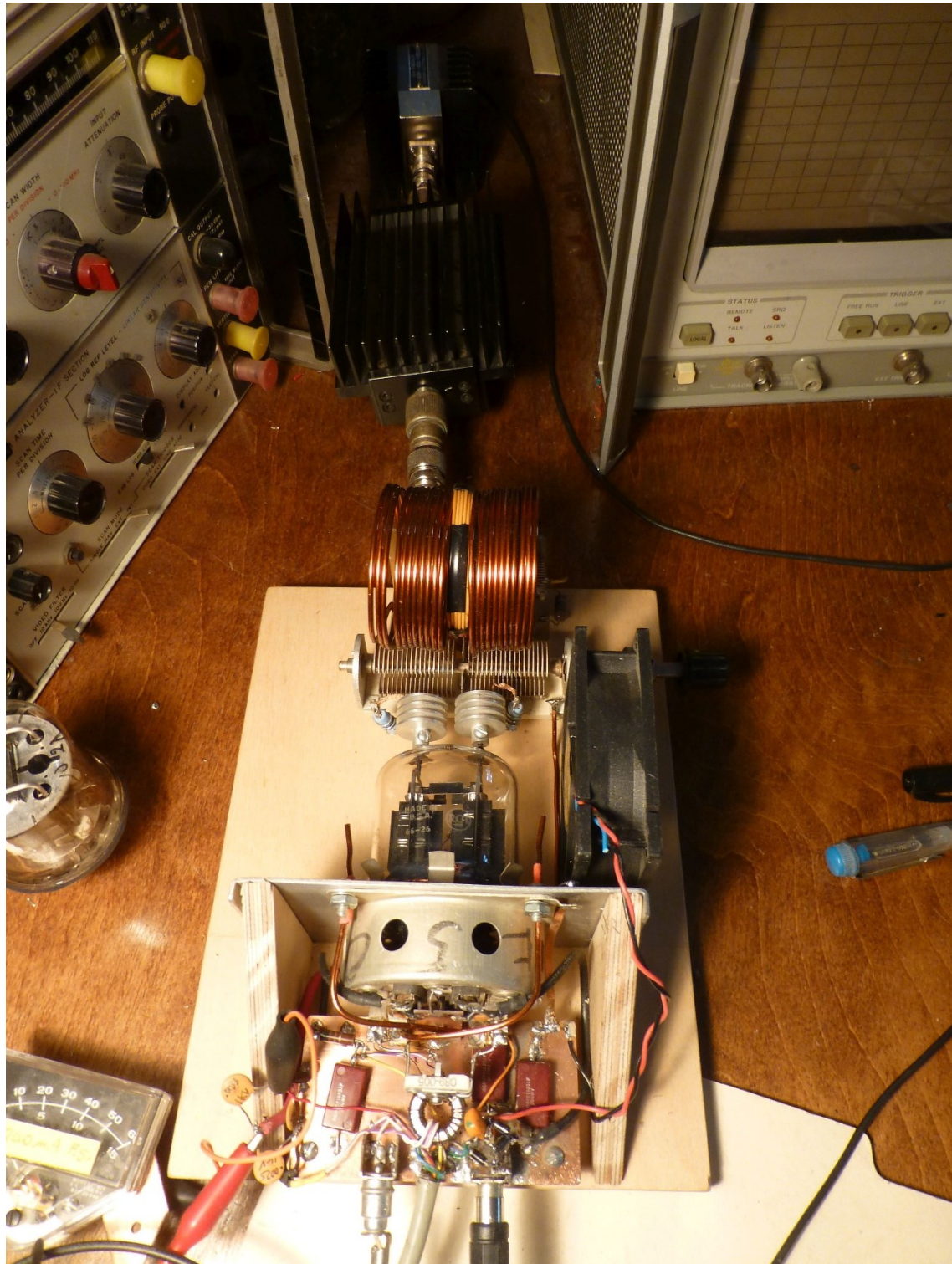

Transmitter load testing into power attenuators.



Complete transmitter with (L-R) power supply, VFO, driver, and 829B amplifier.

APPENDIX A: POWER TRANSFORMER DESIGN

The switching power supply's power transformer runs at 55 KHz, with square wave drive. The primary inductance required depends on what maximum magnetic flux level the selected core material can support. The flux density in a transformer's core is independent of the load or power transferred by the transformer. Flux density is determined by the operating voltage and frequency, number of turns on the primary winding, and core cross-sectional area. We do not want the transformer core to saturate at maximum swings of the flux density over the hysteresis curve of the core material. If that happens, then the magnetizing current would not be limited by the primary's inductance, and it would soar to high levels and destroy the mosfet switches. Ferrite materials can support a few thousand gauss (KG) of core flux density before saturation, but much lower levels of flux density must be used as we increase frequency, due to increasing core losses. I chose to shoot for a maximum flux density,

B_{max} , of around 1000 gauss. Once the core is selected, then it is easy to determine the minimum required number of primary turns and resulting primary inductance, for a given peak flux density in the core. Knowing the required output voltages, the required secondary winding turns are then easily calculated. First we start with the magnetics design.

Transformer design is based on Faraday's Law, which relates the rate of change of magnetic flux in the inductor, to the induced voltage appearing across the terminals of the coil of wire in the inductor. Faraday expressed his law in the well-known relationship $E = L \frac{di}{dt}$, where E is the voltage across the inductor winding, L is the inductance in henries, and $\frac{di}{dt}$ is the rate of change of inductor current vs time. Thus, there is no voltage appearing across any inductor unless there is a *changing* current through it, or a *changing* magnetic field in the inductor's core. From this expression it can be determined that the magnetic flux in an inductor's core is a function of the product of (amperes x turns) in the inductor. Flux density (the amount of magnetic flux per unit area in the core) is similarly a function of the ampere-turns product. In the linear central region, the flux density follows the expression $B = \mu H$, where B is flux density in Gauss and H is the magnetomotive force in Oersted, and μ is the permeability of the core material ($\mu = \mu_0 = 1.0$ for an air core).

In a transformer, the inductance of the driven winding (usually called the *primary* winding) together with the applied changing voltage, determines the *magnetizing current* of the transformer. In a transformer being driven by a symmetrical waveform, the hysteresis curve (magnetic flux density vs magnetomotive force, the so-called "BH Curve" occupies four quadrants, as shown below:

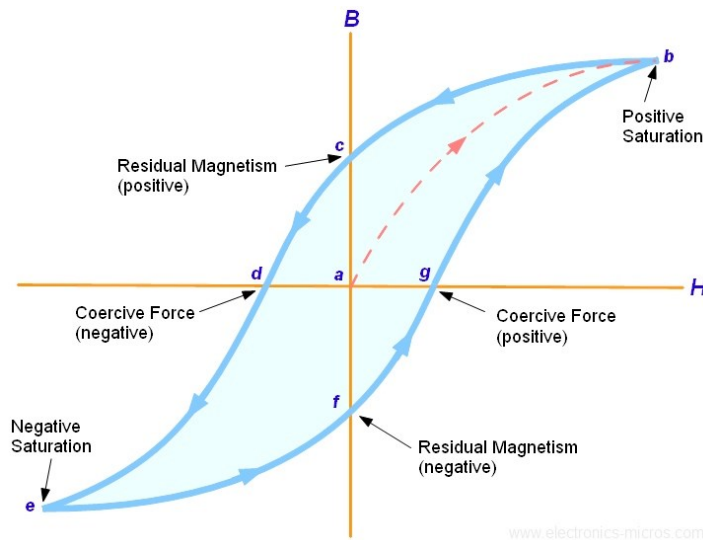

Above: Magnetic core hysteresis curve.

Faraday's Law, in the form it is used in transformer design, is:

$$N_p = \frac{V_p(t_{on}) \times 10^8}{(\Delta B)(A_e)}$$

Where

N_p is the number of primary turns in the transformer

t_{on} is half the square wave drive period, ($T/2$)

V_p is the peak voltage applied to the primary

A_e is the cross-sectional area of the core, in sq cm

ΔB is the total flux swing in gauss, from $-B_{max}$ to $+B_{max}$

For this off-line design, where we intend to operate directly from the 120 VAC line voltage as the power source, the peak primary voltage is the DC value of the full-wave rectified and filtered AC line voltage. This is approximately the peak value of the line voltage, minus two rectifier diode drops,

$$\text{Peak primary voltage} = \sqrt{2}(\text{AC line voltage, RMS}) - 2 \text{ volts} = \mathbf{168V}$$

Since the transformer is driven from an H-bridge circuit, as previously explained, the primary then sees a square wave of +/- 168V, or **336V p-p**, and the desired flux density swings from -1000G to +1000G.

The core chosen is an Amidon EA-77-188 cup core and bobbin. (It was the largest pot core in my junkbox). I like pot cores because of the easy-to-wind circular bobbin, and the excellent coupling and magnetic shielding afforded by the enclosed magnetic circuit of the cup core arrangement. This type 77 ferrite core has a cross-sectional area of 2.02 cm^2 and an inductance factor A_l of 7680 mH/1000turns, values taken from the Amidon data sheet.

From Faraday's equation above, since we now know all the parameters required, we can solve for the unknown N_p , the number of required primary turns, by rearranging Faraday's equation:

$$N_p = \frac{168 \times 8.6 \times 10^8}{(2000g)(2.02)} = \mathbf{36 \text{ turns.}}$$

To allow a bit for margin on the flux density, let's make it **38 turns**. Now, when we have output voltages of just a few volts (such as the 12.6V filament winding we need), then the volts per turn becomes an important factor, because if we had several volts per turn, we may not be able to obtain the required 12.6V for the lowest output winding, since turns must occur in integer numbers (1, 2, 3, etc), with no fractional turns possible. In this case, we have 168V/38T or **4.42 volts per turn** for the primary. So a secondary of just two turns would provide 4.42x2 or 8.8VDC,

too low, and 3 turns would provide 13.3VVDC, which is about right, allowing some drop in interconnecting leads to the tube. The increased number of primary turns also lowers the peak flux density in the core a bit, which we can now calculate by rearranging the previous equation for primary turns:

$$N_p = \frac{V_p(t_{on}) \times 10^8}{(\Delta B)(A_e)}$$

$$\Delta B = \frac{V_p(t_{on}) \times 10^8}{N_p A_e} = \frac{168 \times 8.6 \mu S \times 10^8}{38 \times 2.02} = 1882 \text{ gauss, or } +/- \text{ 941 gauss}$$

This is below the 1000 gauss allowed. (The lower the Bmax, the less we are stressing the core, magnetically).

With the primary turns known, we can now calculate the turns required for the secondary windings:

For the 625V plate winding, $N_s = 625V / 4.42 \text{ volts/turn} = 141.4$, use **145T** for additional sag allowance and rectifier diode drops.

For the 200V screen winding, $N_s = 200 / 4.42 = 45.2$ turns, use **46** turns.

For the -45V bias winding, $N_s = 45 / 4.42 = 10.2$ turns, use **11** turns.

All windings except the primary and 13V secondary are low current, not exceeding a small fraction of an ampere. So we can use small gauge wire (such as #28 enameled, since a copious supply is found in the junk box). For the 13V secondary, since there are only 3 turns required, I used some triple-insulated #18 wire for the 13V winding. For the primary, even though the peak current is over an ampere, the length of the winding is small enough to allow using 28 gauge wire for the primary. It is double-insulated with Kapton insulating tape, to isolate the primary from all secondary windings with about a 2KV breakdown voltage. (The primary winding must withstand any common-mode line transients as well as the peak primary voltage, since the entire primary circuit is operating directly from the rectified line voltage, and is therefore 'floating' with the AC mains input). It would have been best to use triple-insulated wire for the primary, which is rated for full AC line isolation in transformers, but I did not have any small-gauge triple-insulated wire. But for ham homebrew purposes, the Kapton tape provides all the insulation I need.

A trial winding of a single layer of #28 wire on the bobbin was made in order to ascertain if there was enough core winding (window) area for the total windings. It looked close, but adequate, so the primary was wound first, followed by the secondaries, in decreasing voltage order, which places the 3 turn heavy filament winding last, on the outside of the bobbin. Between each winding, a single layer of Kapton tape (only a mil or two in thickness, but rated for 1KV) was used as inter-winding insulation. Leads for the high voltage plate and primary windings were sleeved with

thin-walled Teflon sleeving where they exited the bobbin and core, to provide additional insulation from the core and nearby circuits outside the transformer.

Knowing the number of primary turns, the primary inductance can now be calculated from the Inductance factor A_L given in the Amidon data sheet:

$$L_p = \frac{A_L N_p^2}{10^6} = \frac{(7680)(38^2)}{10^6} = 11 \text{ mH}$$

The peak primary exciting current (the magnetizing current) can be calculated from the well-known equation for current vs time in an inductor,

$$\text{Amps/Sec} = \text{slope of the } I \text{ vs } T \text{ curve} = \text{Volts/Inductance}$$

For the primary,

$$\text{Amps/Sec} = 168\text{v}/11\text{mH} = 1.53 \times 10^4 \text{ Amp/Sec}$$

When switching with a 55KHz square wave, the period is 1/55000 or 18.2 uSec. But the winding is only on for half of the 18.2 uSec period, or 9.1 uSec, and then it reverses. So the peak magnetizing current in the primary winding is

$$1.53 \times 10^4 \times 9.1 \text{uSec} = 0.14\text{A}$$

The power input to the power supply can be estimated by assuming an overall efficiency number, say 65% conservatively. The total output power of the switching supply is approximately 625V x 0.2A + 200V x .025A + 45V x .020A + 13V x 1.3A = 125 + 5.0 + 0.9 + 16.9 = 148 Watts. Thus the input power is 148W/0.65 = 227W. With 168V on the primary, the primary load current is about 227W/168V = 1.4A DC. The transformer's exciting current should be, for a good design, a small fraction of the full load input current. In this case it is 0.14/1.4A = 10%, which is OK.

GATE DRIVE TRANSFORMER DESIGN.

The gate drive transformer requirements are simpler than the main power transformer. It operates at only low winding voltages and currents, and its main purpose is to electrically isolate the ground-referenced 55 KHz square wave generator from the gates of the four floating mosfet switches in the H-bridge, which it drives. I had, in the junkbox, one of the smallest ferrite E-cores that Amidon sells, their E-77-188 part, only about 3/4" square and 3/16" thick. The plastic bobbin can accommodate up to over 190 turns of #28 wire.

The magnetics design uses the same approach as the power transformer of course. In this case, the requirement is to operate at +/-12 V 55 KHz

input square wave from the pulse generator, and deliver four isolated square wave outputs of about +/- 10V or so, which is sufficient to drive the mosfets into and out of saturation. The material is the same ferrite material, Amidon's type 77, as the power transformer's cup core. The area of the E-core is .225 sq cm, much smaller than the cup core. The maximum flux density goal remains +/-1000 Gauss or so. Again, from Faraday's law,

$$N_p = \frac{V_p(t_{on}) \times 10^8}{(\Delta B)(A_e)} = \frac{13(8.6\mu S) \times 10^8}{2000(0.225)} = 25 \text{ turns}$$

The primary winding must be well insulated from the secondaries because it is used to isolate the 120V mains from the ground-referenced secondary circuits. I decided to use some 22 gauge Teflon insulated flexible wire for the primary, and for the secondaries the same 28 gauge enameled wire used in the power transformer. The Teflon insulated wire is much thicker than the 28 gauge enameled, so it is wound last.

With the primary being driven by +/- 13V, or 26V pk-pk, and for 20V pk-pk on each secondary (this drives the mosfet gates with +/- 10V relative to their sources, guaranteeing that they will be turned on and off, completely), we need a turns ratio, primary/secondary, of 26/20 or 1.3. This makes the secondaries 19 turns each. The four secondaries are wound as a quadrafilar (4 wires in parallel) winding of 20 turns, followed by a single winding of 25 turns for the primary. The primary and secondary windings just fit the available winding area on the E-core's bobbin. The resulting inductance of the primary winding is calculated from the AL factor in the Amidon data sheet of 1290 mH/1000t,

$$L_p(mH) = \frac{A_L N_p^2}{10^6} = \frac{(1290)(25^2)}{10^6} = .806mH$$

The peak primary magnetizing current is calculated as before with the power transformer,

$$\text{Amps/Sec} = 13v / 0.806mH = 1.61 \times 10^4 \text{ Amp/Sec}$$

For an ON time of 9.1uSec, peak primary magnetizing current is 16000 x 9.1uSec = +/- **0.15A**. This is the magnetizing current only. It is quite high, albeit usable. But a better design would use a somewhat larger core which with the same number of turns would bring the magnetizing current down, reducing the current demand of the pulse generator. This would, in turn, reduce the pulse generator's dissipation and filter capacitance of the 13V local DC supply.

In addition the pulse generator output must supply the net current required to charge and discharge all four of the mosfet gates, at a 55 KHz rate. (Even though the mosfets are voltage-controlled devices, it requires power to repetitively charge and discharge the gate capacitances,

since coulombs/sec = amperes, and amperes supplied from a driving voltage equates to power (volt-amperes) drawn from the source).

The total gate charge of the 21N50C3 500V mosfet used, is specified as 95 nanocoulombs (nC). Thus, four times this, or 380nC total must be charged *and discharged* from the four gates, every 9.1 uSec half-cycle, using 10V as a source to accomplish this. Hence there are a total of 4 charges and 4 discharges per half cycle, which is a total of 8 charges and discharges in 9.1uSec. Since amperes is coulombs per second (the time rate of change of charge), then the primary current consumed from the UC3825A outputs is,

$$\text{Primary current} = \text{secondary current} \times \frac{\text{Secondary}}{\text{Primary}} \text{turns ratio} = \left(\frac{95\text{nC} \times 8}{9.1 \text{ uSec}} \right) \times \left(\frac{10\text{V}}{13\text{V}} \right) = 64\text{mA}$$

Thus, the total primary current required from the pulse generator outputs is the sum of the two currents calculated above, or **0.21A**. In the actual circuit, the average DC current required from the pulse generator IC (UC3825B), is somewhat less than the calculated value of 210mA, due to the fact that the square-wave does not have a 100% duty cycle, but has a few percent of OFF time, during each cycle. Also, there is some sag in the 12V supply to the pulse generator, due to the winding resistances of the small 2.4VA transformer used to provide the local grounded supply source, as well as the sag in the filter capacitors of this supply, which are filtering the full-wave rectified 60 Hz transformer output winding. The measured current drain of the UC3826B in the working circuit, is about 175mA. The concern over current demand from the pulse generator is to minimize the resulting power dissipation in the chip's totem-pole output drivers. A slightly larger transformer core could reduce the drive current substantially by increasing the inductance for the same number of turns, or even using more turns to further increase the inductance and lower the drive current. (If available, a larger core would have been preferable, so as to lower the magnetizing current further and reduce the current supplied by the UC3825A outputs).

APPENDIX B: LTSPICE SIMULATION OF SWITCHING POWER SUPPLY

Linear Technology Corp's free Spice simulation software is a wonderful tool for homebrew hams. If I can, I always simulate any circuit idea I have in mind, before I even breadboard the circuit. In addition, simulations gives one a greater insight into how circuits do (and perhaps even more importantly, do not) work. A switching power supply is an excellent example of this, because a major error in the design can have catastrophic (and noisy!) results when high voltages and high currents (and high energy storage) are involved.

This switching supply is easily modeled in LTSpice. The PWM generator is simply modeled here as a dual pulsed voltage source, with the appropriate frequency and duty cycle. Below are the LTSpice simulation schematic, and some results of the simulation. A 'transient' simulation was run to show the waveforms at interesting points in the circuit, during initial turn-on and for several milliseconds after, with a 600V plate load connected. Note the large inrush current into the line rectifier's filter capacitor, 130 amps in the first half cycle of line frequency. This is enough to weld the contacts on miniature toggle switches, so for the present I just wired it on, and plug in the line cord when I want to use the transmitter. I may come up with a soft-start circuit which can fit inside the rather tightly cramped power supply box.

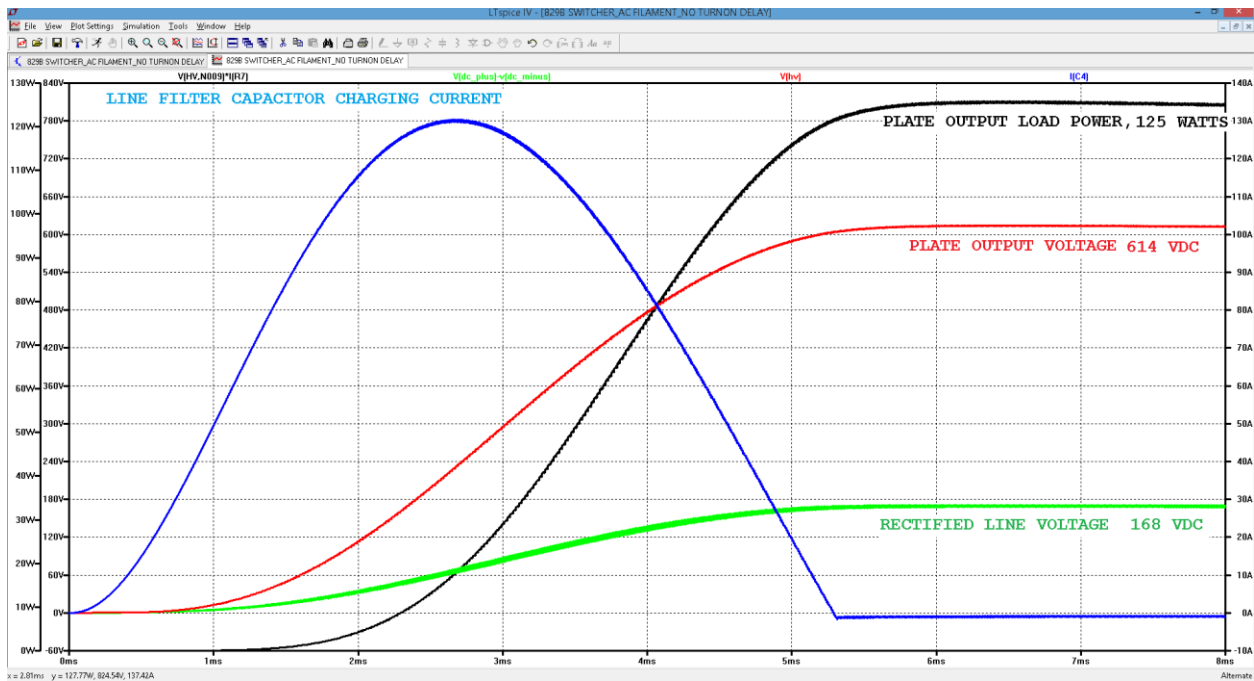

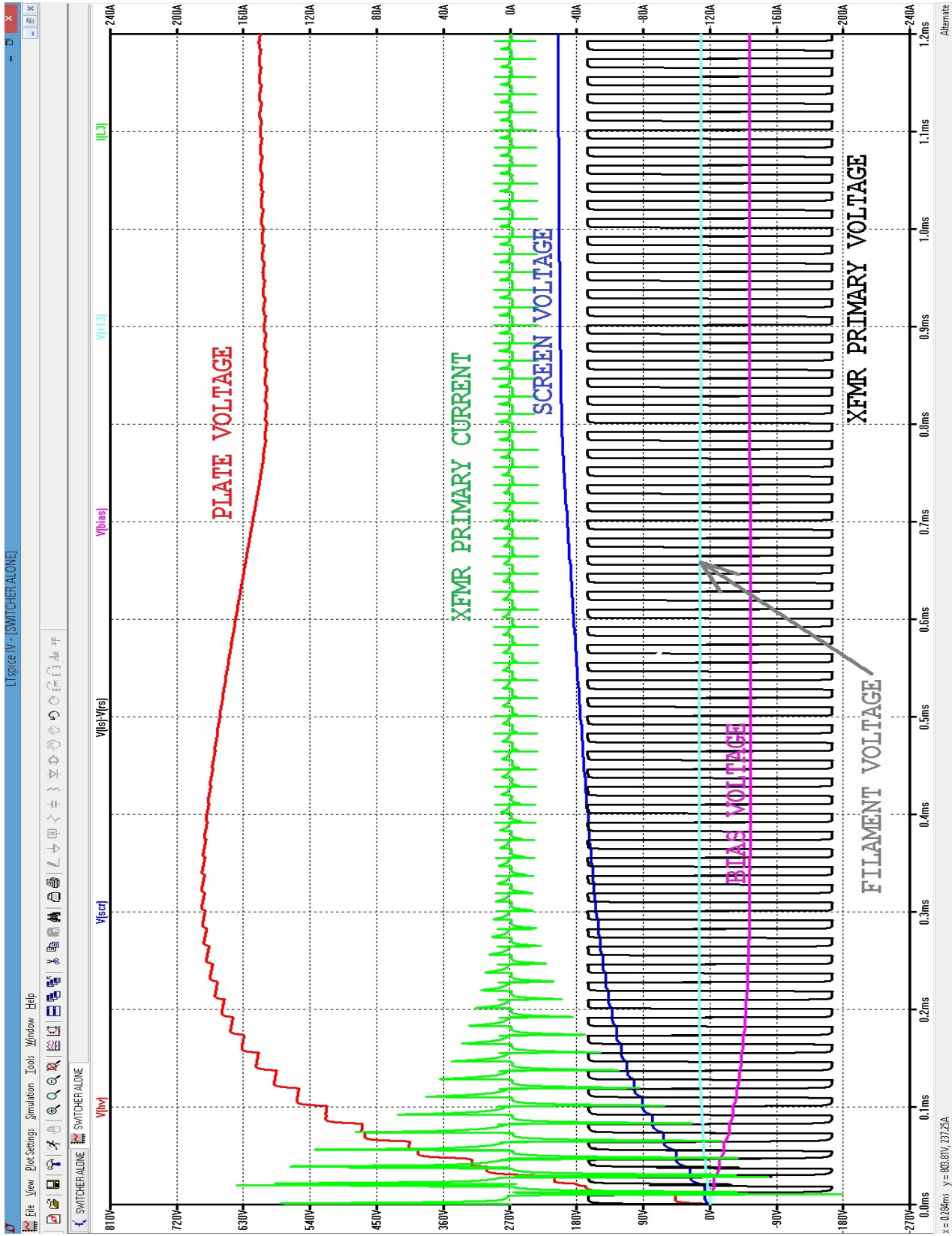

Above: Power supply startup LTSpice transient run

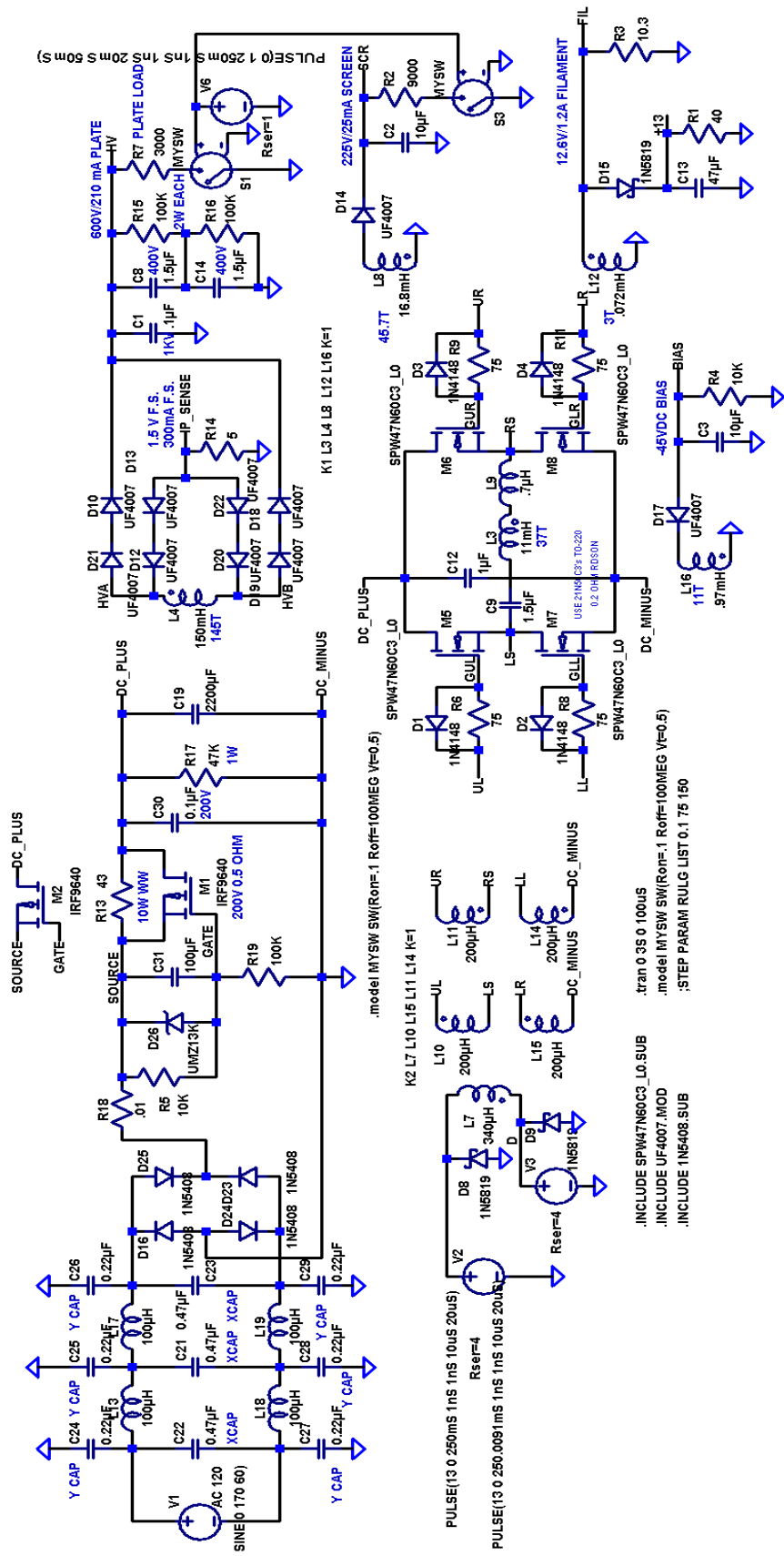

```

.model MYSW SW(RonF=1 Roff=100MEG Vf=0.5)
.tran 0 8S 0 100us
.model MYSW SW(RonF=1 Roff=100MEG Vf=0.5)
.STEP PARAM RULG LIST 0.1 75 150

```

```

.INCLUDE SPW47N60C3_LO.SUB
.INCLUDE UF4007.MOD
.INCLUDE 1N5408.SUB

```

APPENDIX C: LTSPICE SIMULATION OF THE 829B AMPLIFIER.

I always look for any excuse to simulate a new design or idea that I have. It is almost as much fun for to use Spice simulation to predict behavior, as it is to come up with a circuit idea in the first place. A little time spent perusing the 829B plate characteristic curves on the data sheet, together with a pentode tube mathematical model obtained from Koren's website, see:

www.normankoren.com%2FAudio%2FTubemodspice_article.html&usg=AFQjCNGFbfM2Io6EH_A5IPZb1J9OXZ1QDQ . This enabled me to make a 'test fixture' for the

tube, in LTSpice. The fixture is nothing more than the tube in a schematic which has its elements connected to appropriate power supplies. The mathematical equations that describe the complex relationship between the control grid voltage and the resulting plate current have been fairly well understood for many years. Each tube has its own set of numerical constants that make up the terms contained in the equations, so these constants have to be determined for the particular tube being modeled. The circuit is then simulated in the circuit, using stepped values of grid and plate voltage, which results in plotting of the characteristic plate current vs grid voltage curves. Then by comparing the simulated curves with the one in the data sheet, I was able to converge on a set of approximate tube parameters used in Koren's equations for a pentode tube model. I soon realized that for a CW transmitter, one needs only to match the end points of the swing in plate current and grid voltage (ie, the end points of the desired load line). The load line for a resonant load is a straight line, connecting the maximum and minimum plate currents and voltages. All intermediate values are irrelevant, since the tube spends almost no time here. It is either at full power output (key down), or zero power output (key up). This allowed, by trial and error, a fairly rapid determination of the three constants needed in Koren's model. These constants determine the 'knee' plate voltage (where the curves start to bend sharply downward), the spacing of the plate current lines vs grid voltage, and the cut-off region (high plate voltage and low plate current).

With the three parameters thusly determined, it was not difficult to place the tube's new .subcircuit file into an LTSpice schematic, after creating a new symbol for the tube.

Below is the LTSpice schematic of the 829B test fixture, which plots the plate characteristic curves, for comparison with the published curves.

Again, only the end points of the desired operating region were of importance to match.

THESE PARAMETERS GIVE GOOD CURVE FIT TO DATA SHEET AT (2KV, 1.1A, 0V) AND (2KV, 0.15A, -50V) AND (450V, 0.95A, 0V)
 PARAMS CHANGED FROM 6CL6 MODEL: KVB = KNEE VOLTS = 70V. MU = 8.5. KP = 17 SETS HI PLATE V HIGH & NEG GRID V.

.SUBCKT PENTODE1 1 2 3 4 ; A G2 G1 C (PENTODE1)

CURVE FIT BY W6JL

* RCA

* library format: LTSpice 12-Oct-2011

X1 1 2 3 4 PENTODE1 MU=19 EX=1.351 KG1=469.3 KG2=812 KP=25 KVB=10 VCT=0.00 RGI=2000 CCG=5.7p CPG1=0.560p CCP=2.5p ;

.ENDS 4CX250B

PENTODE EQUATION FROM NORMAN KOREN WEB PAGE.

.SUBCKT PENTODE1 1 2 3 4 ; A G2 G1 C

RE1 7 0 1MEG ; DUMMY SO NODE 7 HAS 2 CONNECTIONS

E1 7 0 VALUE={V(2,4)/KP*LOG(1+EXP((1/MU+V(3,4)/V(2,4))*KP))}; E1 BREAKS UP LONG EQUATION FOR G1.

G1 1 4 VALUE={((PWR(V(7),EX)+PWR(V(7),EX))/KG1*ATAN(V(1,4)/KVB))}

G2 2 4 VALUE={((EXP(EX*(LOG((V(2,4)/MU)+V(3,4)))))/KG2)}

*G2 2 4 VALUE={PWR(if(V(2,4)/MU+V(3,4) < 0 , V(2,4)/MU+V(3,4) , 0) ,EX)/KG2}

RCP 1 4 1G ; FOR CONVERGENCE A - C

C1 3 4 {CCG} ; CATHODE-GRID 1 C - G1

C2 1 3 {CPG1} ; GRID 1-PLATE G1 - A

C3 1 4 {CCP} ; CATHODE-PLATE A - C

R1 3 5 {RGI} ; FOR GRID CURRENT G1 - 5

D3 5 4 DX ; FOR GRID CURRENT 5 - C

.ENDS PENTODE1

;step param F 27.8e6 28.7e6 0.1e6

.lib Koren_Tubes.cir

;tran 0 3uS 0 1nS

;ac dec 1000 1e6 50e6

.STEP PARAM PLATE 0 600 5

.STEP PARAM GRID 0 -30 10

.op

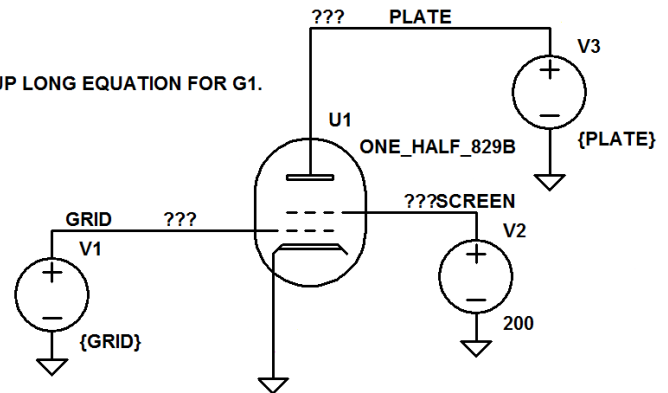

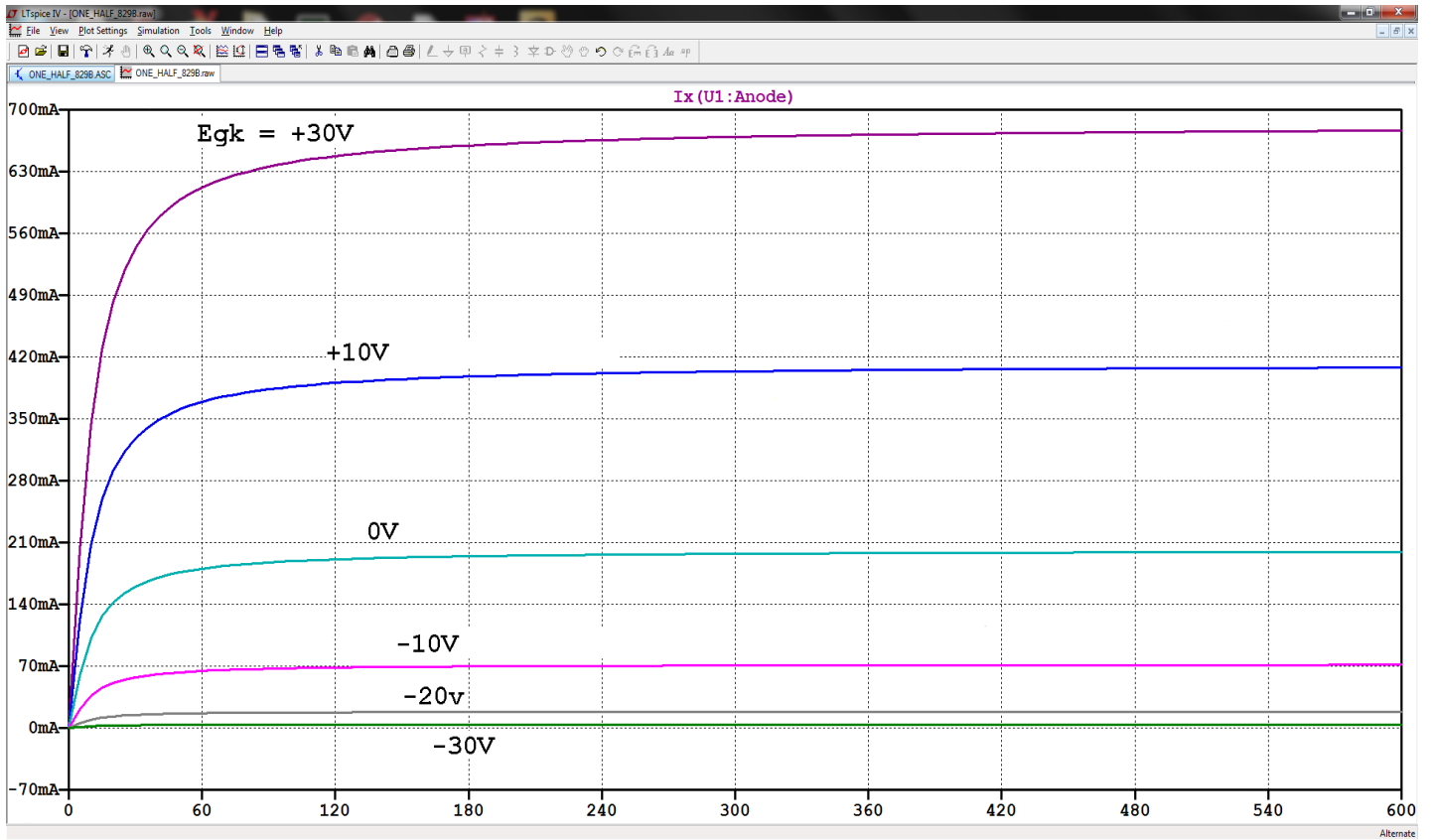

Plotted plate characteristic curves for $\frac{1}{2}$ 829B, using test fixture circuit.

```
.SUBCKT ONE_HALF_829B 1 2 3 4 ; A G2 G1 C (PENTODE1)
* VIA KOREN'S TUBE MODELING DATA. MU AND KVb VALUES CHOSEN BY W6JL TO FIT 829B PLATE CURVE SWING END POINTS
* library format: LTSpice 12-Oct-2011
X1 1 2 3 4 PENTODE1 MU=19 EX=1.351 KG1=469.3 KG2=812 KP=25 KVb=10 VCT=0.00 RGI=2000 CCG=5.7p CPG1=0.560p CCP=2.5p ;
.ENDS 4CX250B
```

```
.SUBCKT PENTODE1 1 2 3 4 ; A G2 G1 C
RE1 7 0 1MEG ; DUMMY SO NODE 7 HAS 2 CONNECTIONS
E1 7 0 VALUE={V(2,4)/KP*LOG(1+EXP((1/MU+V(3,4)/V(2,4))*KP))}; E1 BREAKS UP LONG EQUATION FOR G1.
G1 1 4 VALUE={PWR(V(7),EX)+PWR(V(7),EX)/KG1*ATAN(V(1,4)/KVb)}
G2 2 4 VALUE={EXP(EX*(LOG(V(2,4)/MU+V(3,4))))/KG2}
*G2 2 4 VALUE={PWR((V(2,4)/MU+V(3,4) < 0 , V(2,4)/MU+V(3,4) , 0) , EX )/KG2}
RCP 1 4 1G ; FOR CONVERGENCE A - C
C1 3 4 {CCG} ; CATHODE-GRID 1 C - G1
C2 1 3 {CPG1} ; GRID 1-PLATE G1 - A
C3 1 4 {CCP} ; CATHODE-PLATE A - C
R1 3 5 {RGI} ; FOR GRID CURRENT G1 - 5
D3 5 4 DX ; FOR GRID CURRENT 5 - C
.ENDS PENTODE1
```

```
.lib Koren_Tubes.cir
:op
;STEP V2 .32 0 1
```

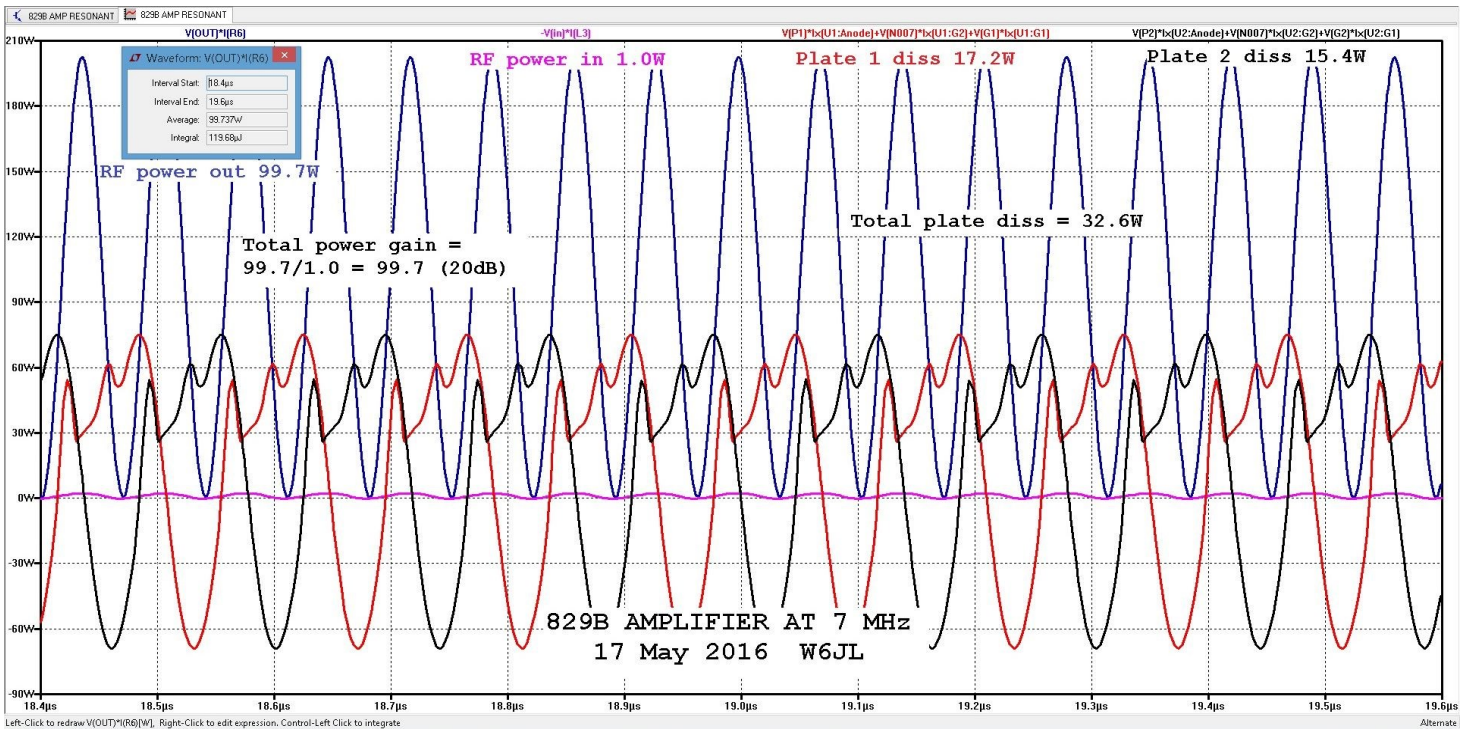
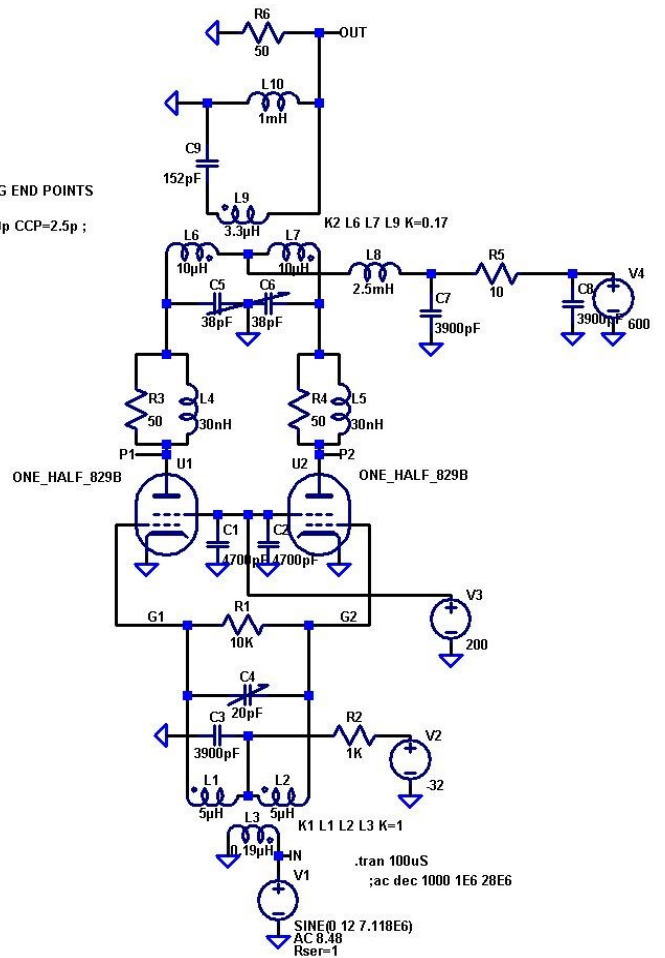

Power waveforms and average values in 829B amplifier at 100W output.

APPENDIX D: **ADDING PLATE OVERCURRENT SHUTDOWN TO THE POWER SUPPLY**

After beginning to use the amplifier on the air it was found that if there was a sudden surge in plate current, due to an arc in the output, or even if the amplifier were keyed into an open circuit (antennas disconnected) accidentally, this could result in blowing the fuse in the 165V DC supply circuit to the H-bridge . This fuse had been included in an attempt to protect the mosfets in the bridge from any sudden overload due to a fault somewhere. The tuning capacitor used in the push pull output circuit has plate spacing somewhat marginal for the power level and voltages used. If only a brief arc occurred during tuning, this would pop the 165V fuse. I decided that it would be a great convenience if I did not have to install a new fuse every time some brief fault occurred in the plate circuit for any reason.

The UC3825N chip has a feature that is intended for cycle by cycle overcurrent sensing, using an internal comparator that trips if the sensing voltage at pin 9 exceeds 1 volt. By sensing the plate current using a high voltage opto-isolator in the 600V plate circuit, then the overtrip voltage can be generated at some desired current, and the supply should immediately shut down, recovering quickly whenever the fault was removed. This turned out to be fairly easy to accomplish; see the LTSpice simulation schematic below. It works very well; a short to ground can be placed in the plate supply and held there, and the power supply will immediately shut down, and make a normal soft start on its own as soon as the short is removed. This is actually overkill, but I've left it this way; it makes the transmitter even a wee bit more eclectic :o).

